

FENDER RACK™

VERTICAL
BIKE
STORAGE



A SPACE SAVING & SIMPLE BIKE STORAGE SYSTEM

CycleSafe Fender Rack™ System:

Fender Rack™ System holds (1) bike is a secure and economical solution for storing bikes with built in locking capability. The Fender Rack vertical storage system is space efficient, parking the bike against a wall which opens up floor space and allows easy accessibility. The versatile Fender Rack design is suitable for indoor or outdoor use, available in durable polyester powdercoat finish.

“J” hook style hangers create stress on the wheelsets of bike rims found on today's bicycles. CycleSafe's Fender Rack supports the bikes front wheel in a configuration that minimizes damage, while allowing the use of a cyclist's lock to secure the frame and wheel to the rack.

Simply roll the bike up to the Fender Rack, grab the bikes front brake and seat, lift and place bike over the hook and allow bike to settle into tire guard. This easily allows the use of a variety of locks and ability to attach gear.



The vertical storage system is space efficient, parking the bike against the wall which opens up floor space and allows easy accessibility

FEATURES & BENEFITS

- Heavy duty 3/4" square tube frame.
- Two mounting holes 12" apart for 5/16 dia. lag screws.
- Two tamper resistant 5/16" lag screws are included with lag shield for concrete installations.
- Create additional space efficiency with 45° angle kit.
- Durable polyester powdercoat black finish.
- Fender Rack allows attachment of other bicycle gear such as helmets, gloves or other accessories.
- Coated Fender Rack protects the bike frame and finish.
- Allows clearance for pedestrian pathways or storage.
- Custom colors available upon request.
- Easy to install, simple to use.

MULTIPLE MOUNTING OPTIONS

- Mounting Fender Rack to wall studs on 16" centers is typical.
- Combine Fender Rack with 45° angle mounting brackets to increase pedestrian walkways.
- Transit Rack System available with stability strap mounted on a sturdy galvanized frame.
- Contact CycleSafe for additional multiple mounting options.



PH 616.954.9977 FAX 616-954-0290
888.950.6531 CYCLESAFE.COM INFO@CYCLESAFE.COM

©2009 Cycle-Safe, Inc. *Cycle-Safe® and ProPark® are Federally registered trademarks.



FENDER RACK™

VERTICAL
BIKE
STORAGE

Specifications



Cycle-Safe's Product Line



LOCKERS

The ProPark® bicycle locker from Cycle-Safe is an attractive, pad-mounted modular system that's easy to install, requires minimal maintenance, and provides the ultimate in bicycle security.



CYCLEPORT SHELTERS

A modular bicycle shelter system which features a composite canopy with a tubular frame in contemporary design. May be specified with a variety of side walls and bike racks for weather protected short term use.



U2 RACKS

Cycle-Safe's "inverted U" type bike racks are the leading edge in technology for bike rack parking and offer the best of short-term cycle parking. The inverted U-rack design for two bicycles is widely regarded as the recommended standard for modern bicycles.



VINTAGE RACKS

Vintage Racks by Cycle-Safe are a novel blend of the old and the new. They capture the charm of traditional ornamental bicycle standards. Vintage Racks were developed in response to urban planners' efforts to recreate historic streetscapes as counterpoints to the hustle and bustle of the modern world.

DIMENSION DRAWING:

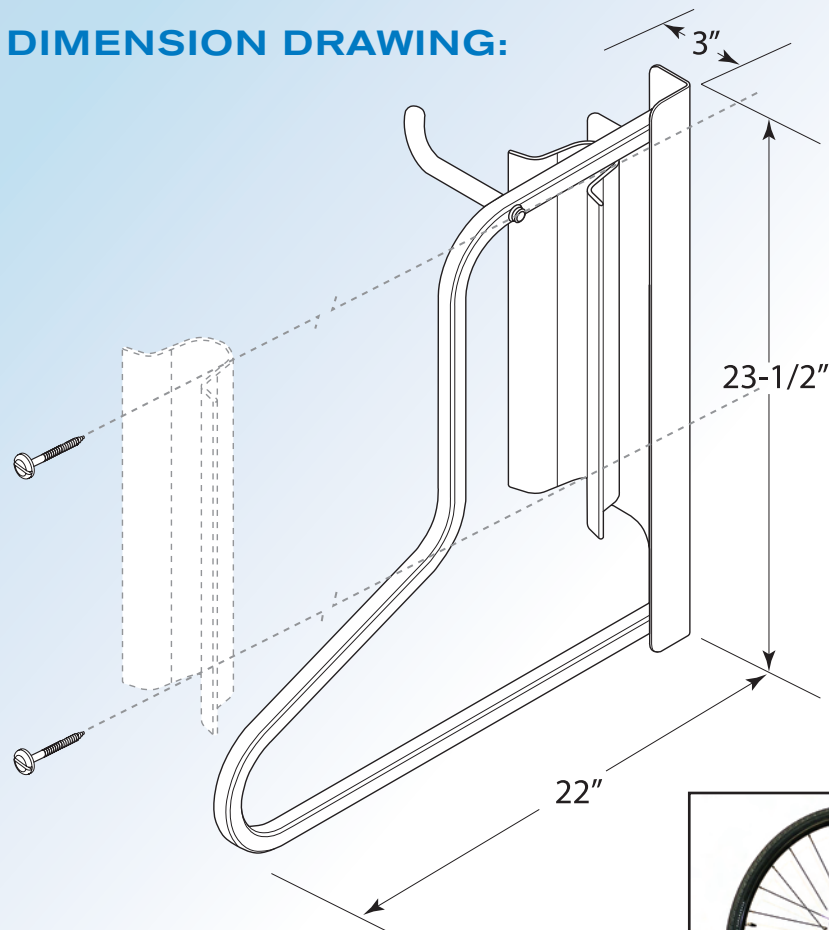

- Product: CycleSafe Fender Rack part# 17560
Capacity: Holds 1 bike
Material: Heavy duty 3/4" square tube frame
Finish: Durable polyester powdercoat finish
Custom colors upon request
Mounting: Tamper resistant 5/16" lag screws included
Concrete lag shield included
Optional 45° angle bracket



*U-Lock compatible to secure
bike and frame*

ORDER INFORMATION:

- Fender Rack #17560 - (BK) black
- Tire Guard #17568
- Concrete lag shield #17504
- Extra lag screw #17505
- 45° angle bracket #17513

Ships 2 per box, lag screws and shields included.

Contact us for more information



PH 616.954.9977 FAX 616-954-0290
888.950.6531 CYCLESAFE.COM INFO@CYCLESAFE.COM

©2010 Cycle-Safe, Inc. *Cycle-Safe® and ProPark® are Federally registered trademarks. Printed on recycled paper.



LR4.1.012-B
Rev. 3.22.16