

Tell Us What You Think!



Sarisinfrastructure.com

Submit Your Installation Photos!

Nothing makes us happier than seeing our
infrastructure products out in the wild!

Submit your photos at the link below.

www.sarisinfrastructure.com/contact/submit-photos



Thanks for purchasing a Saris Infrastructure bike rack!

The rack you are about to install was USA born and bred from our manufacturing facility in Madison, WI. Under our watchful eye it was bent and welded. After having a finish applied locally, it has made its way to you.

Bicycle racks are amazing pieces of infrastructure. A simple bent piece of steel can unlock the incredible tool the bike can become. A secure parking rack makes communities and businesses healthier and happier. They eliminate one of the major obstacles for people not choosing to travel by bike: secure bike parking at their destination. So put a smile on your face as you place this rack into position because you are making the world a better place.

Please read and understand the following instructions before beginning your installation.

Everyone here at Saris wants you to be happy with this product.

Please contact us at sales@sarisinfrastructure.com or 800-783-7257 should you need anything.



Flange Mount

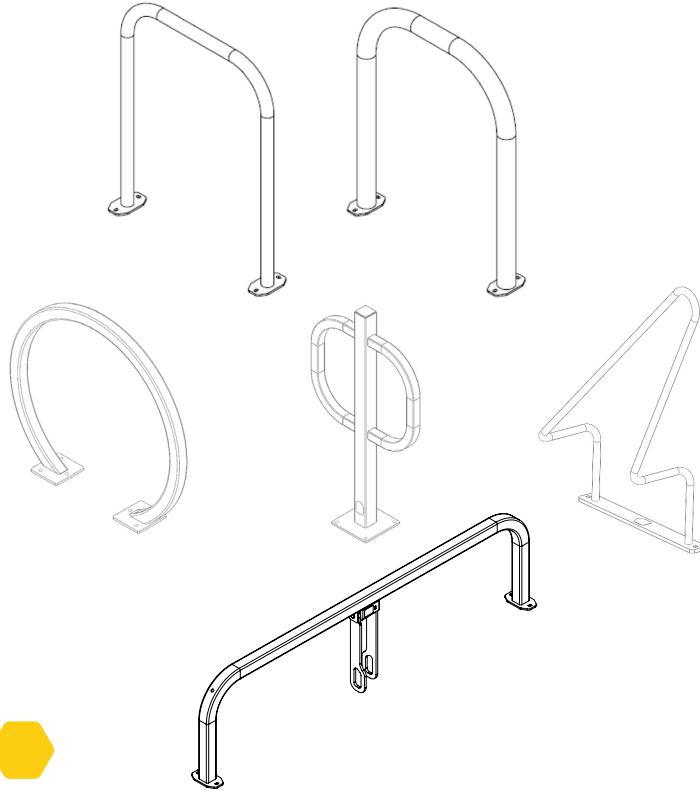

- Bike Dock, Post and Ring, Cargo Dock Temporary Mount (#28879), Temporary Secure Mount (#26270) & Permanent Spike Anchor (#6266) – sold separately.
- Circle Dock Temporary Mount (#29163), Temporary Secure Mount (#29164) & Permanent Spike Anchor (#6266) – sold separately.
- Bike Perch Temporary Mount (#34232) & Temporary Secure Mount (#34233) – sold separately.

Required Tools

Sold by Saris

- Anchor Set Tool #25683



- Saris Security Socket #31424
(only needed for temporary secure installation).

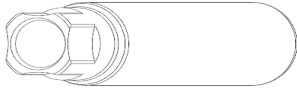

Installer Provides

- Tape measure
- 1/2" masonry drill bit drill (hammer drill recommended)
- Hammer
- 3/8" drive ratchet
- Marker or pencil
- 7/32" hex key
- Level



Installation Instructions

1. Place the rack in the desired location (see setbacks document for reference). Use a marker or pencil to outline the holes of the flange onto the base material. We recommend checking the hole locations after each new anchor is placed. Ensure the holes are at least 6" away from any cracks in the base material.
2. The concrete anchor (a.k.a. "drop-in anchor") is a female anchor designed for use in solid concrete only and cannot be used in brick or block base material. The anchor size is designated by the inside diameter of the anchor. The diameter of the hole to be drilled is the same size as the outside diameter of the anchor which is $\frac{1}{2}$ ".
3. When fastening to solid concrete with a drop-in anchor, a hole must first be drilled into the concrete using a hammer drill, as it will drill the best quality hole. Once the bit is inserted into the hammer drill, the depth of the hole to be drilled can easily be set by using the depth gauge on the drill or by wrapping the bit with tape at the required depth. We recommend a drill depth of 1-5/8" deep so that the anchor just sets down flush with the surface.

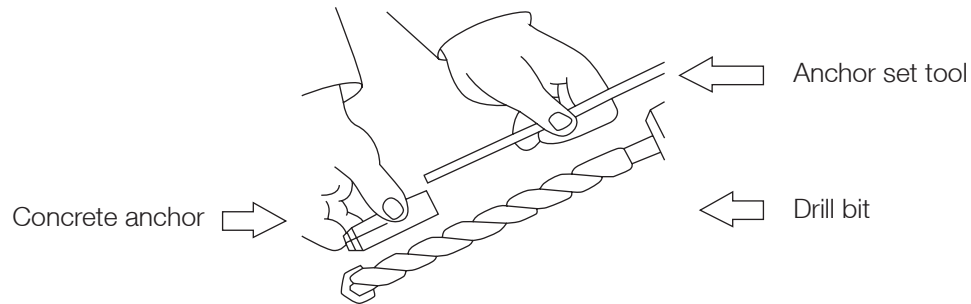

- Before drilling, it is important that eye and ear protection are used. Make sure the hammer drill is in hammer mode and start drilling your hole. Continue drilling until the tape on the bit or the drill gauge meets the base material – this means that the required depth has been reached.

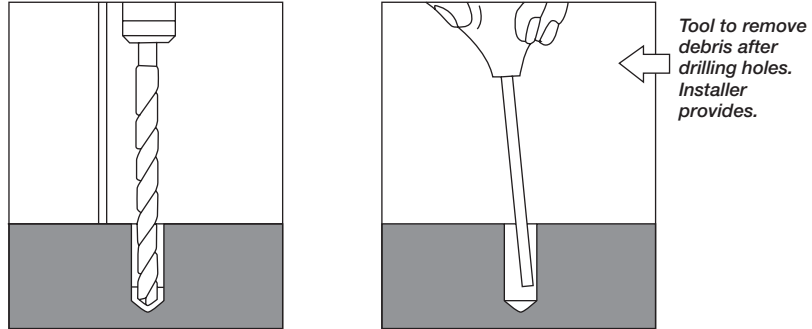

- Before proceeding with installation, the hole must be cleaned of all concrete dust to ensure proper fastening. Use a wire brush, vacuum, or compressed air to clean out the hole completely.

- Next, insert the drop-in anchor with the open side up. Tap lightly to get the anchor flush with the base material.
- Now, take the setting tool and insert it into the anchor. Strike the setting tool with the hammer several times until it no longer moves down. This will ensure the anchor is properly set.

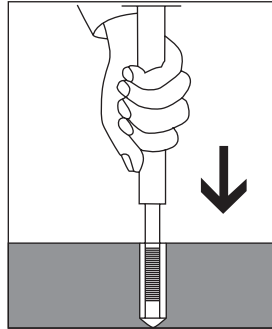

- Place the rack over the anchors. For temporary installation, you will be using four button head hex bolts. Use the 7/32" hex wrench to tighten the button head hex bolts.

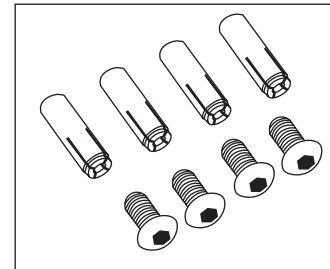

Temporary mount hardware

For temporary secure installation, you will be using two studs with two Penta nuts and two button head hex bolts. Be sure to alternate between Penta nuts and button head bolts. You will thread the stud into the anchor prior to installing the Penta nuts using the Penta socket. Use the 7/32" hex wrench to tighten the button head hex bolts.

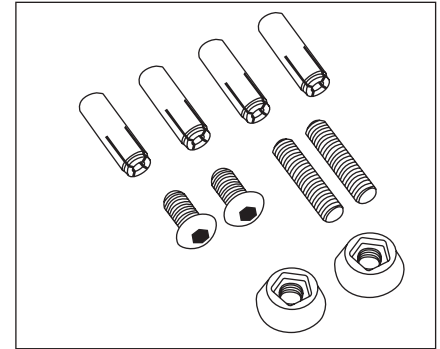

Temporary secure mount hardware

9. Before tightening everything down, make sure the rack is level and adjust accordingly with washers underneath the flanges.

10. Permanent Mount (#6266 – sold separately)

- a. Determine desired location of unit.
- b. Using a 3/8" masonry drill bit, drill through the flange mount and into the concrete 4-1/4".
- c. Clear the hole of dust and other material.
- d. Drive a spike through the flange mount and into the hole, until the head of the spike is seated on the flange mount.

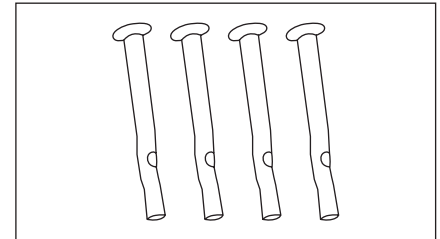

Permanent mount hardware



Bike Dock – Corral Mount

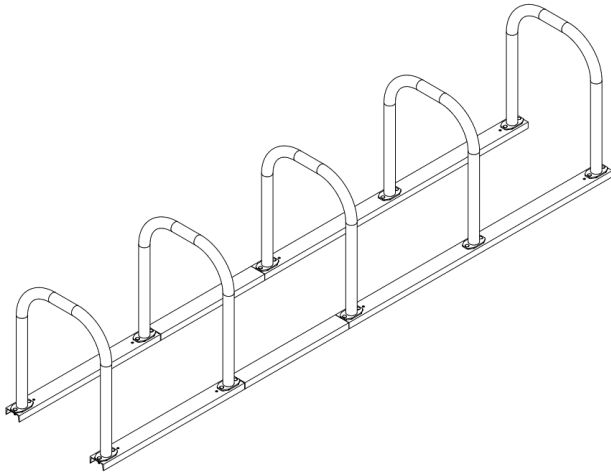

Corral Assembly

1. Level prop rails up on blocks of wood to provide ample clearance for a socket wrench underneath.
2. Line up docks onto rails so that the flange holes line up with the rail holes.

Note: Rails are designed with two mounting configurations (angled and straight). Be sure to line the holes up accordingly.

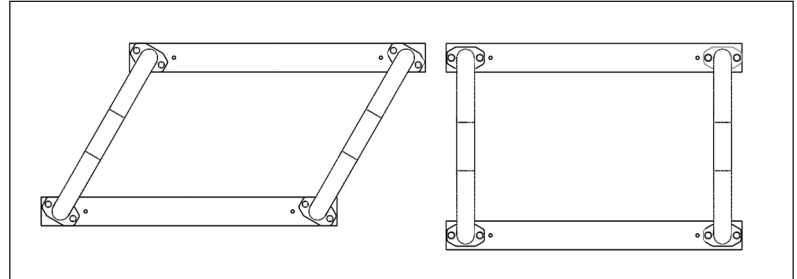

3. Place carriage bolts through the dock flanges and tighten the nut underneath finger-tight.

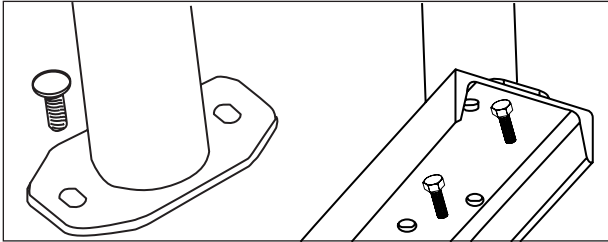

4. If you are assembling an 8, 10, or 12-bike corral, you will need to connect the rails with the corral joiner. The carriage bolts for these locations will pass through the dock flange, the rail, and the joiner tab.

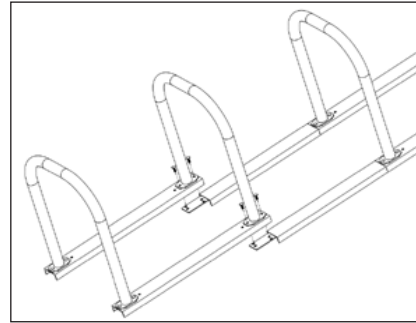

5. Once all docks are assembled onto the rails, verify that they are aligned and parallel.
6. Go back and tighten the nuts using a 9/16" socket.
7. It is not required to anchor the corral. However, there are anchoring holes at all four corners of the corral to allow anchoring to a variety of surfaces. Proceed to the next section of the manual for the various anchoring methods.

Corral and Bike Perch Rail Mount Anchoring

A. Permanent Mount Installation (#6259 – Sold Separately)

- 1) Determine desired location of unit.
- 2) Using a 3/8" masonry drill bit, drill through the rail and into the concrete 6-1/4".
- 3) Clear the hole of dust and other material.
- 4) Drive a spike through the rail and into the hole, until the head of the spike is seated on the flange mount.

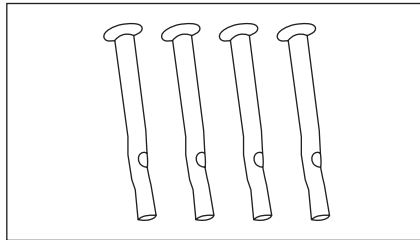

Permanent mount hardware

Bike Perch Rail Assembly

1. Level prop rails up on blocks of wood to provide ample clearance for a socket wrench underneath.
2. Line up Perch Racks onto rails so that the flange holes line up with the rail holes.
3. Insert carriage bolts through the top of Perch flange and tighten the nut underneath.

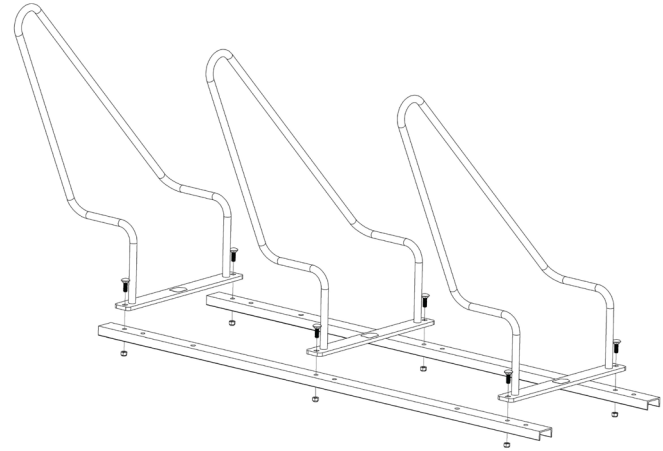

Configurations:

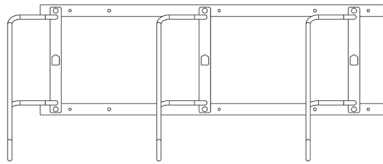

3 Perch – Double Rail (#34428)

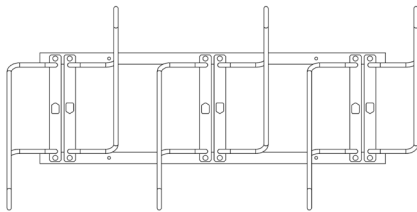

6 Perch – Double Rail (#34429)

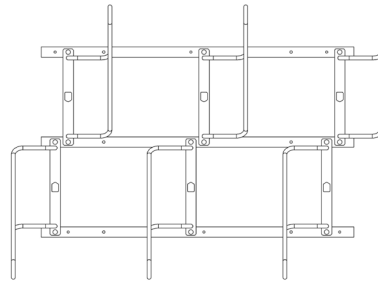

6 Perch – Triple Rail (#34434)

B. Tools Needed for Installation (Sold by Saris) – Sold Separately –

- Temporary Mount (#29173) & Temporary Secure Mount (#29172) Installation Anchor Set Tool #25683



- Saris Security Socket #31424 (only needed for temporary secure installation).

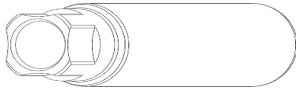

Tools Needed for Installation (Installer Provides)

- Tape measure
- 1/2" masonry drill bit drill (hammer drill recommended)
- Hammer
- 3/8" drive ratchet
- Marker or pencil
- 7/32" hex key
- Level

***DO NOT THROW AWAY THE PENTA SOCKET AFTER COMPLETING THE INSTALLATION.
YOU WILL NEED IT TO REMOVE THE EQUIPMENT IF THAT IS NECESSARY.**

1. Place the rack in the desired location (see setbacks document for reference). Use a marker or pencil to outline the holes of the flange onto the base material. We recommend checking the hole locations after each new anchor is placed. Ensure the holes are at least 6" away from any cracks in the base material.
2. The concrete anchor (a.k.a. "drop-in anchor") is a female anchor designed for use in solid concrete only and cannot be used in brick or block base material. The anchor size is designated by the inside diameter of the anchor. The diameter of the hole to be drilled is the same size as the outside diameter of the anchor which is 1/2".
3. When fastening to solid concrete with a drop-in anchor, a hole must first be drilled into the concrete using a hammer drill, as it will drill the best quality hole. Once the bit is inserted into the hammer drill, the depth of the hole to be drilled can easily be set by using the depth gauge on the drill or by wrapping the bit with tape at the required depth. We recommend a drill depth of 1-5/8" deep so that the anchor just sets down flush with the surface.

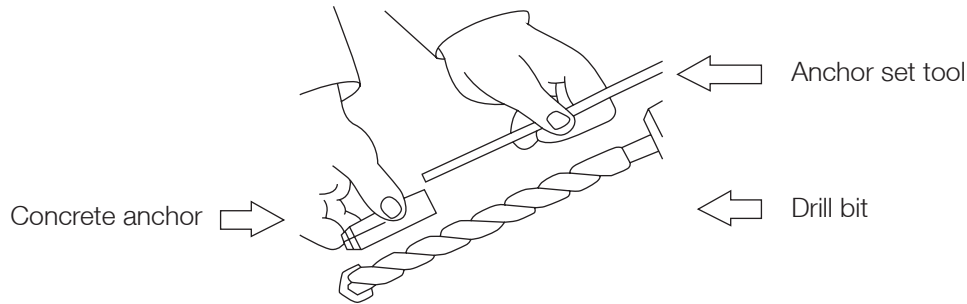

4. Before drilling, it is important that eye and ear protection are used. Make sure the hammer drill is in hammer mode and start drilling your hole. Continue drilling until the tape on the bit or the drill gauge meets the base material – this means that the required depth has been reached.

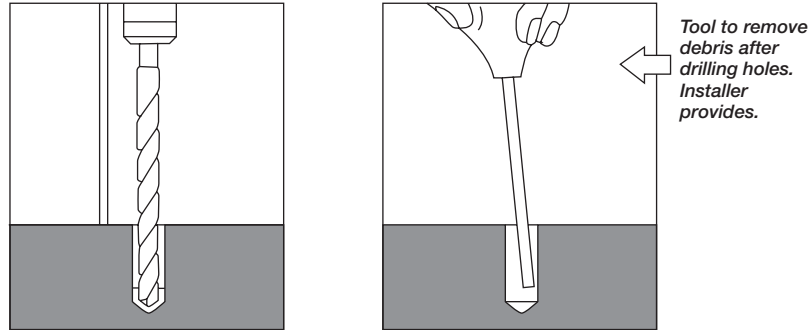

5. Before proceeding with installation, the hole must be cleaned of all concrete dust to ensure proper fastening. Use a wire brush, vacuum, or compressed air to clean out the hole completely.

6. Next, insert the drop-in anchor with the open side up. Tap lightly to get the anchor flush with the base material.
7. Now, take the setting tool and insert it into the anchor. Strike the setting tool with the hammer several times until it no longer moves down. This will ensure the anchor is properly set.

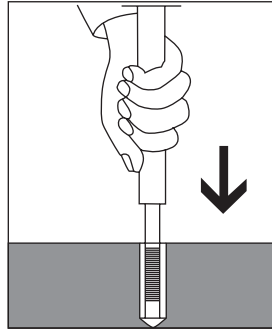

8. Place the rack over the anchors. For temporary installation, you will be using four button head hex bolts. Use the 7/32" hex wrench to tighten the button head hex bolts.

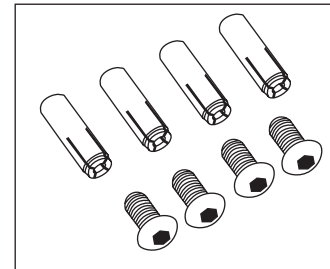

Temporary mount hardware

For temporary secure installation, you will be using two studs with two Penta nuts and two button head hex bolts. Be sure to alternate between Penta nuts and button head bolts. You will thread the stud into the anchor prior to installing the Penta nuts using the Penta socket. Use the 7/32" hex wrench to tighten the button head hex bolts.

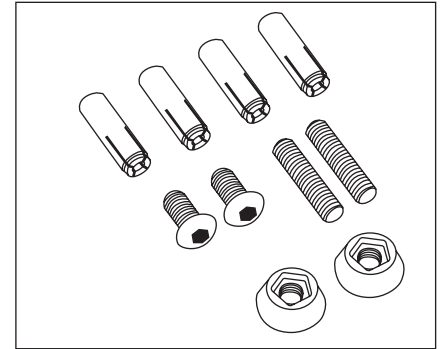

Temporary secure mount hardware

9. Before tightening everything down, make sure the rack is level and adjust accordingly with washers underneath the flanges.

WARRANTY

WARNING: Manufacturer and seller expressly disclaim any and all liability for personal injury, property damage or loss, whether direct, indirect, or incidental, resulting from the incorrect attachment or inappropriate placement, improper use, inadequate maintenance, or neglect of this product. Placement of this product is beyond control of the manufacturer. It is the end users responsibility to place this product so as to avoid potential pedestrian or playground accidents.

WARRANTY: We warrant this product to the first consumer to be free from defect in material and workmanship for a period of one year from date of purchase. Please retain your sales slip for your records. Any product or part thereof found to be defective within that period will be replaced without charge provided that: (1) the product was not misused; (2) no alterations or modifications were made; (3) its failure resulted from a defect in material or workmanship and not from normal wear expected in the use of the product; (4) the product or part is delivered, freight prepaid, to Saris Products. Manufacturer's only obligation shall be to replace such products or parts proved to be defective.

Saris Infrastructure 5253 Verona Road Madison, WI 53711 (800)783-7257 www.sarisinfrastructure.com