



SARIS
INFRASTRUCTURE

ELECTRIC PUBLIC BIKE PUMP

**OPERATION & MAINTENANCE
MANUAL**

Customer Service
800.783.7257
sarisinfrastucture.com

Tell Us What You Think



sarisinfrastructure.com

**Register your product for updates
sarisinfrastructure.com/registration**

Thanks for buying our Electric Public Bike Pump!

Congratulations and thank you for taking bicycle tire air inflation to the next level. The Saris Infrastructure Electric Public Bike Pump and Air Control Panel put inflating bicycle tires (while hitting your specific PSI level) in the simple and effortless touch of a button.

Please read and understand the following instructions before beginning your installation. In order to make this public-use bike pump as secure and trouble-free as possible, we designed the Electric model to be hard wired to power. It is recommended to have a licensed electrician manage the installation.

Ideal for indoor and outdoor use, the ¼ horsepower air compressor hums along at 40db. That's the same approximate decibel level as birds singing. Feeling calm and relaxed is therefore a natural side effect of using our Electric Public Bike Pump.

Everyone here at Saris Infrastructure wants you to be happy with this product. Please contact us (sales@sarisinfrastructure.com, 800-783-7257) should you need anything.

Tools Needed

Tape Measure
½" Masonry Drill Bit Drill (Hammer drill recommended)
Hammer
Anchor Set Tool (included)
Triple Slot Nut Driver (included)
3/8" drive ratchet
Marker or Pencil
SAE hex key set
Level
Tape Measure
File or sanding tool
Torque Wrench

Parallel Wall or object Setbacks:

Both sides of the electric public bike pump should be at least 12" from walls or other obstructions. If pedestal mounting, we suggest mounting it tight against a wall. See Figure 1.

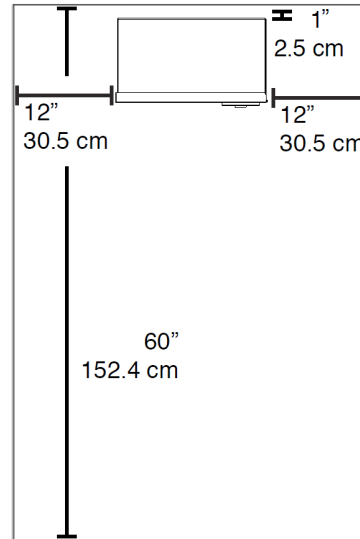

Figure 1: Setbacks

Wall Mounting or Vending Machine Mounting

1. Identify mounting location. Be sure to follow setbacks. The base of the electric pump should be mounted greater than 37" from the ground. If installing on a vending machine, mount in a position that does not inhibit the door opening (we usually mount on the left side of the machine).
2. Choose your mounting surface and fasteners. If mounting to sheet metal, we recommend using #14 sheet metal screws no longer than 3/4". If mounting into concrete, we recommend using a 1/4" masonry screw. If mounting into wood framing, we recommend using #14 wood screws.
3. Before installing the screws, install the rubber backed washers with the sheet metal screws to prevent water intrusion. Be careful not to over tighten the screws during install.

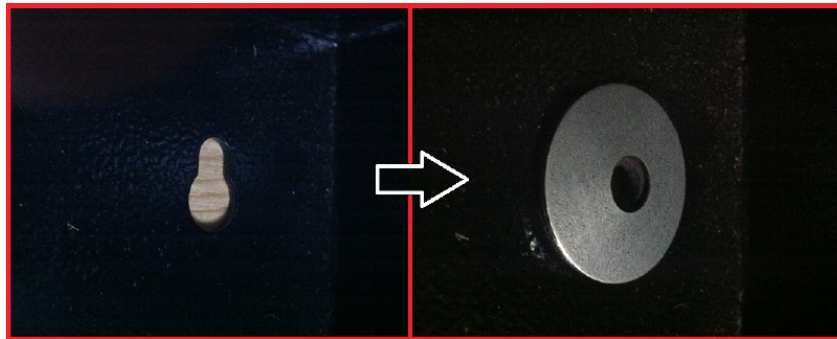

Figure 2

Optional Pedestal Mounting

1. First mount the electric pump on the pedestal using supplied hardware. Ensure 2 spacers are installed between the pedestal and the electric pump cabinet. Tighten four bolts.
2. Pedestal mounting requires an existing power line in the floor. Locate pedestal at power source. The power is designed to go through the pedestal and into the electric pump enclosure. (see setbacks).
3. Use a marker or pencil to outline the holes of the flange onto the base material. We recommend checking the hole locations after each new anchor is placed. Ensure the holes are at least 6" away from any cracks in the base material.
4. The drop in anchor is a female anchor designed for use in solid concrete only and can't be used in brick or block base material. The anchor size is designated by the inside diameter of the anchor. The Saris Infrastructure electric pump pedestal comes with 3/8" - 16 anchors. The diameter of the hole to be drilled is the same size as the outside diameter of the anchor which is 1/2". (Figure 4)

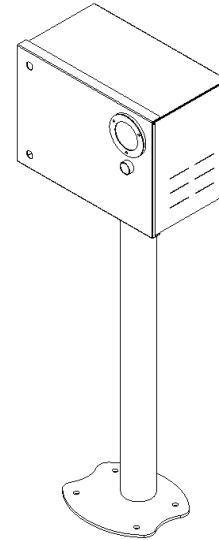

Figure 3

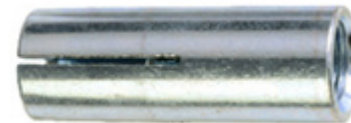

Figure 4

5. When fastening to solid concrete with a drop in anchor, a hole must be drilled into the base material. A hammer drill should be used as it will drill the best quality hole. Once the bit is chucked into the hammer drill, the depth of the hole to be drilled can easily be set by using the depth gauge on the drill or by wrapping the bit with tape at the required depth. We recommend a drill depth of 1-5/8" deep so that the anchor just sets down flush with the surface. (Figure 5)

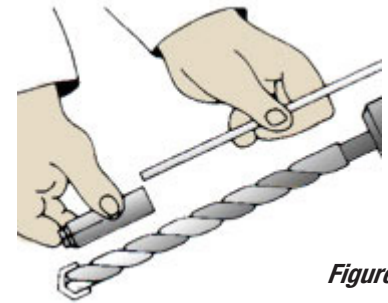

Figure 5

6. Before starting to drill the hole, it is important that eye and ear protection are used. Make sure the hammer drill is in the hammer mode and start drilling your hole. Continue drilling until the tape on the bit or the drill gauge meets the base material- this means that the required depth has been reached. (Figure 6)

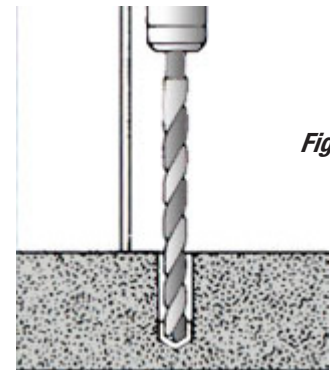

Figure 6

7. Before proceeding with installation, the hole must be cleaned of all concrete dust to ensure proper fastening. Use a wire brush, a vacuum or compressed air to clean out the hole completely. (Figure 7)

8. Next, insert the drop in anchor with the open side up. Drop the anchor into the hole. Tap lightly to get the anchor flush with the base material.

9. Now, take the setting tool and insert it into the anchor. Strike the setting tool with the hammer until the lip of the anchor touches the lip of the setting tool. This will ensure the anchor is properly set. (Figure 8)

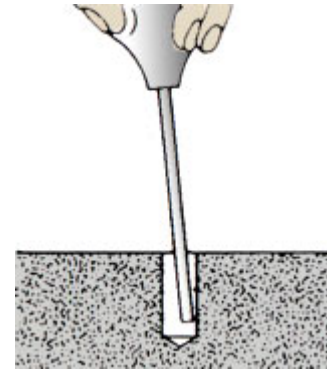

Figure 7

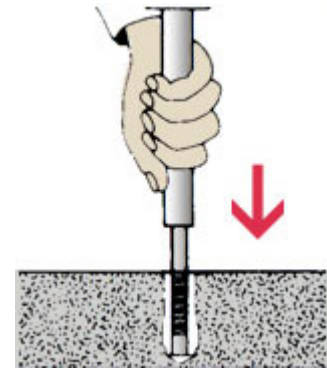

Figure 8

10. Place the pump over the 4 anchors. You will be using 2 studs/tamper resistant nuts and 2 hex bolts (opposite sides from each other). You will thread the studs into the anchors prior to installing the nuts. When tightening the special tamper resistant nuts, always set and first tighten the anchors using standard nuts. DO NOT OVER-TIGHTEN the tamper resistant nut.

10. Check how level the pump is and level with washers.

Electrical Hook Up

1. The Saris Infrastructure electric pump is meant to be installed by a licensed electrician.
2. We suggest running rigid electrical conduit to hard wire the pump. This will help to avoid tampering.
3. The electric pump comes with a testing lead still attached to make it easy to identify the power connections. You will make new connections at the terminal strip.
4. It is important to use a strain relief on the incoming cable to avoid strain on the terminal strip connections.

Air Line Hook up

1. The Saris Infrastructure electric pump comes without the airline connected. Ensure PTFE tape is installed on pipe fitting and tighten hose into fitting at the base of the enclosure. Use two wrenches to tighten.
2. You can now fill up bicycle tires by holding down the pump button.

Required Maintenance

The only required maintenance for the Electric Public Bike Pump is to replace the air chuck every 6 months, or as needed. For a video tutorial on how to change the air chuck, please follow this YouTube link: <https://www.youtube.com/watch?v=4YdWZJi5pb0>

The compressor does not need to be cleaned or drained. If any performance issues arise, please contact your local Approved Saris Infrastructure Distributor.

Pump Operation

Operation instructions for the pump are included on the faceplate of every pump via figure 9 diagram:

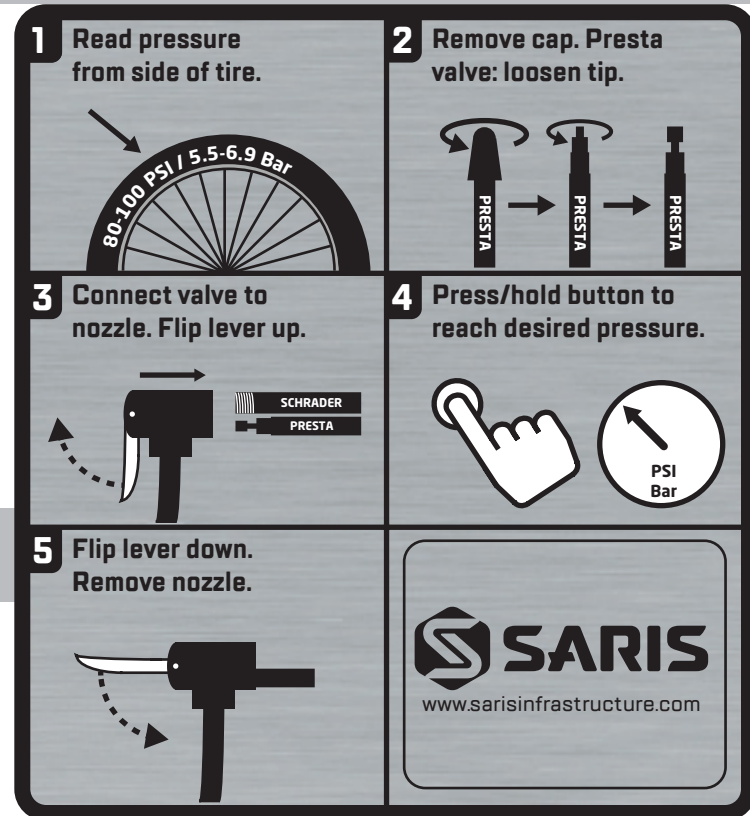
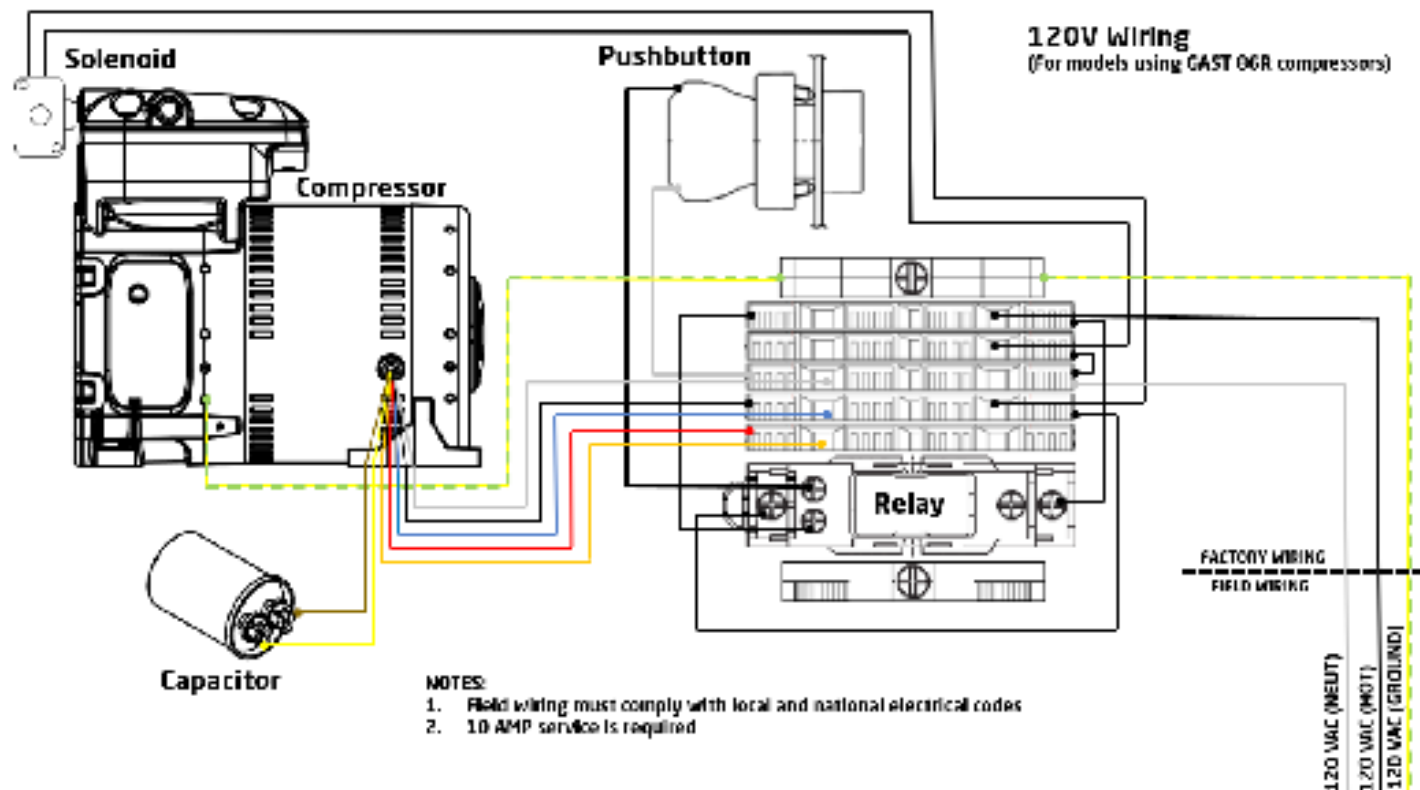
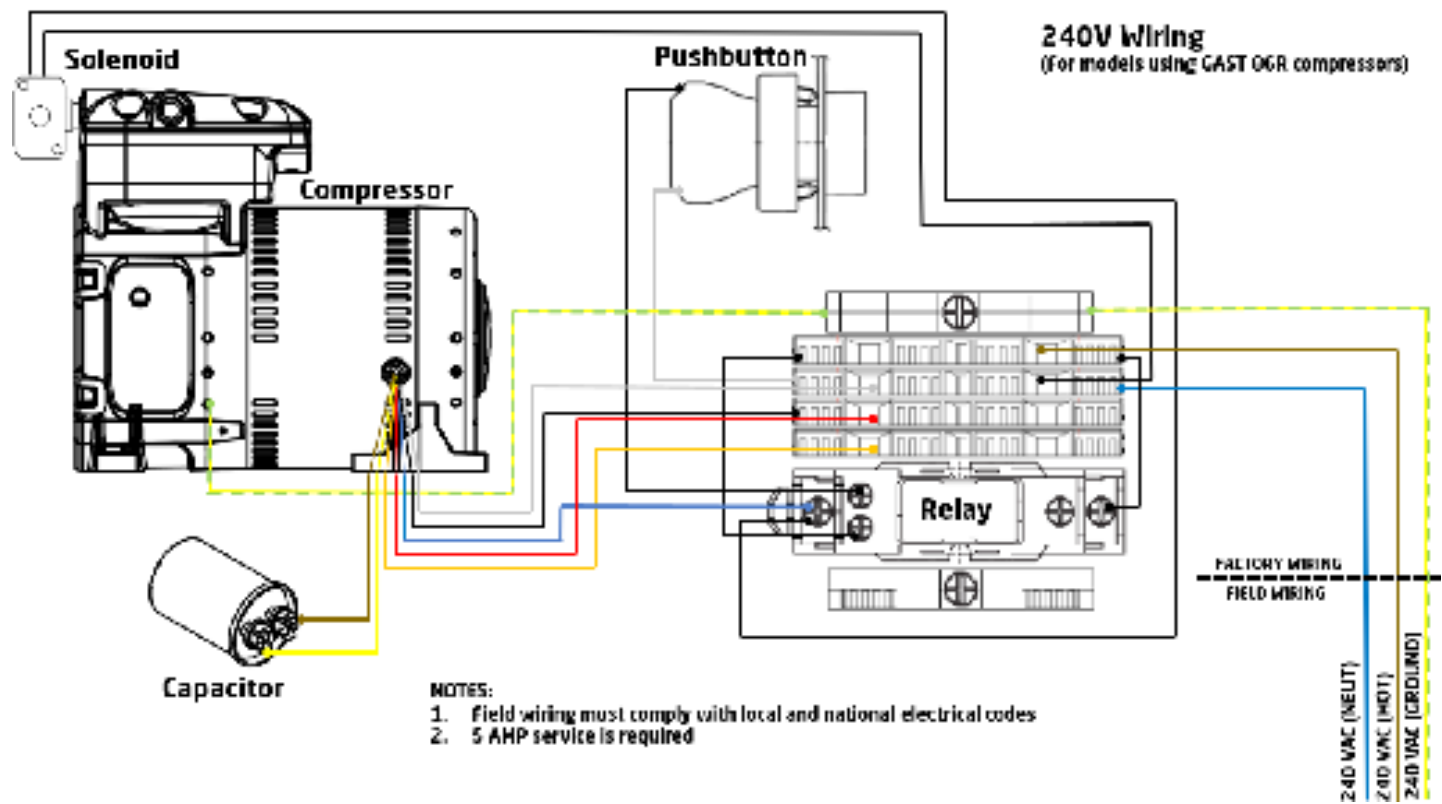

Figure 9





120V Wiring

(For models using GAST ROA compressors)

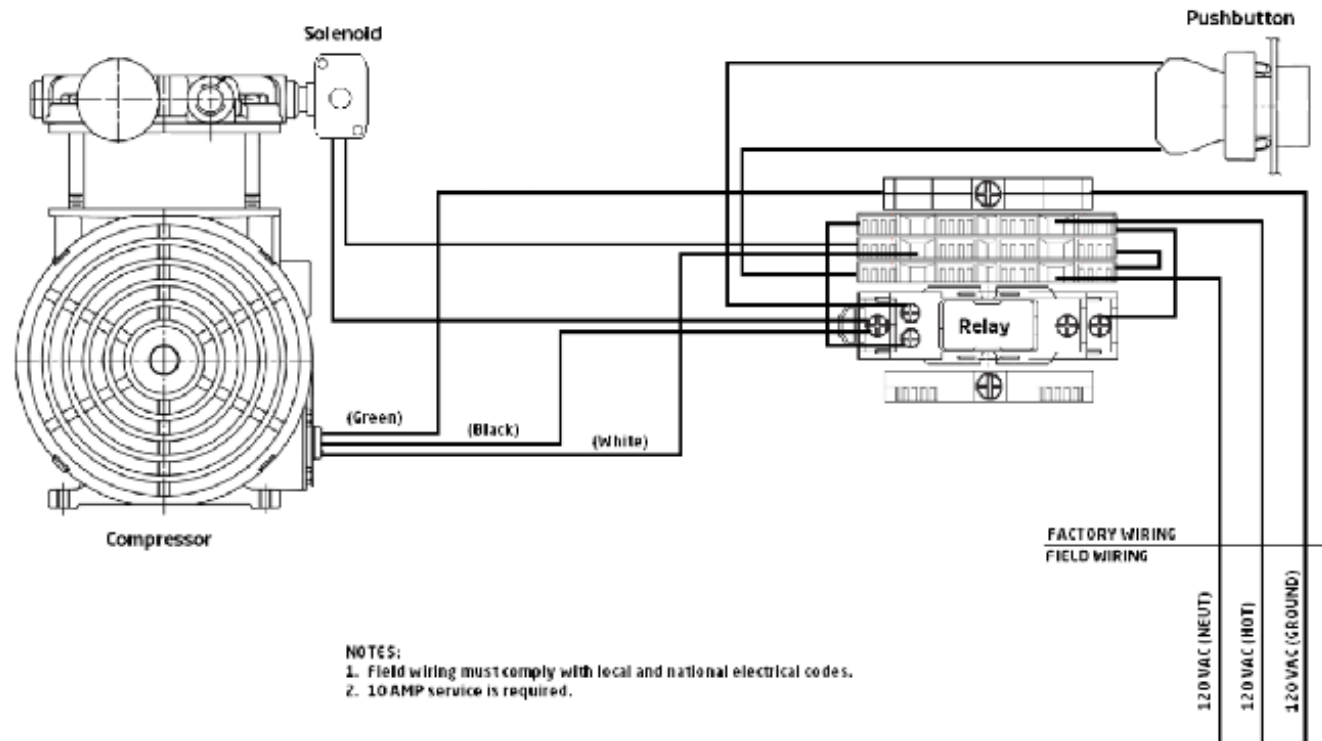

240V Wiring (For models using GAST ROA compressors)

