

eBike Charging Station

Installation Guide



DISCOVER MORE

For more Saris
Infrastructure products,
scan the QR code or visit
[sarisinfrastructure.com](https://www.sarisinfrastructure.com)



Tell Us What You Think!



**[Sarisinfrastructure.com/products/
ebike-charging-station](https://www.sarisinfrastructure.com/products/ebike-charging-station)**

Submit Your Installation Photos!

Nothing makes us happier than seeing our
infrastructure products out in the wild!

Submit your photos at the link below.

www.sarisinfrastructure.com/contact/submit-photos



Thanks for purchasing an eBike Charging Station!

Congratulations on choosing a world-class eBike Charging Station! The eBike Charging Station is a secure and convenient solution to keeping electric bikes safe while they charge.

Designed to accommodate a wide range of personal eBike drive systems, each “charging dock” has a secure, user-accessible locker that contains a 120V or 240V outlet and space for securing each user’s personal bike charger.

Please be sure to read and understand the following instructions before beginning your installation.

Everyone here at Saris wants you to be happy with this product.

Please contact us at sales@sarisinfrastructure.com or 800-783-7257 should you need anything.



Site Prep

Shelter requirements:

Saris recommends a roof or shelter to provide added protection against sun (heat) and rain for the charging connection at the e-bike.

Electrical requirements:

- Power must be supplied to the charging station. This power needs to be installed per the requirements in the National Electrical Code (NEC), ANSI/NFPA 70, or the Canadian Electrical Code (CEC), Part 1, CAN/CSA C22.1 or local requirements where applicable.
- Circuit breaker required. Recommended circuit breaker sizes shown in table.
- Recommend installation to be done by licensed electrician.



CIRCUIT BREAKER SIZES	
MARKET	BREAKER SIZE
USA/CAN	120V, 25A
EU/AS/NZ	230V, 20A
UK	230V, 16A

Installation Instructions

- Review site layout document to determine required space and setbacks for charging stations.
- Determine power source for site. Main power should be connected to a circuit breaker.

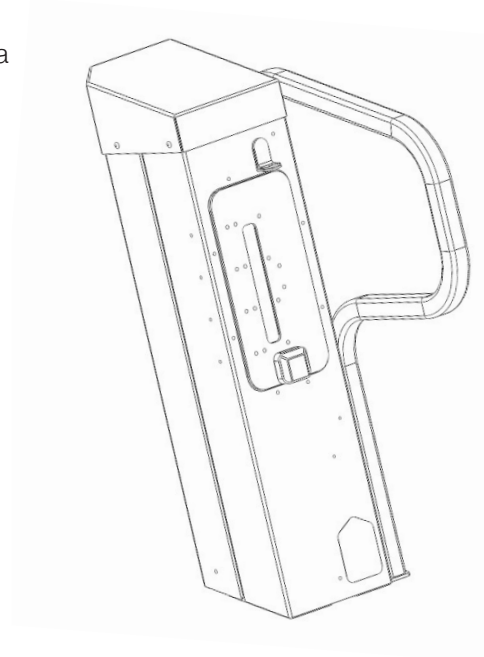

Site layout: Ground Mount System

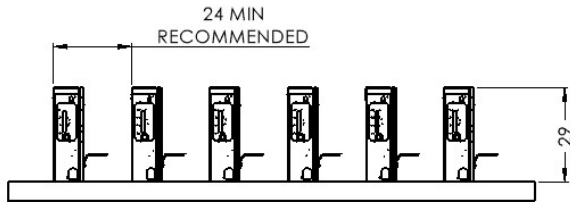
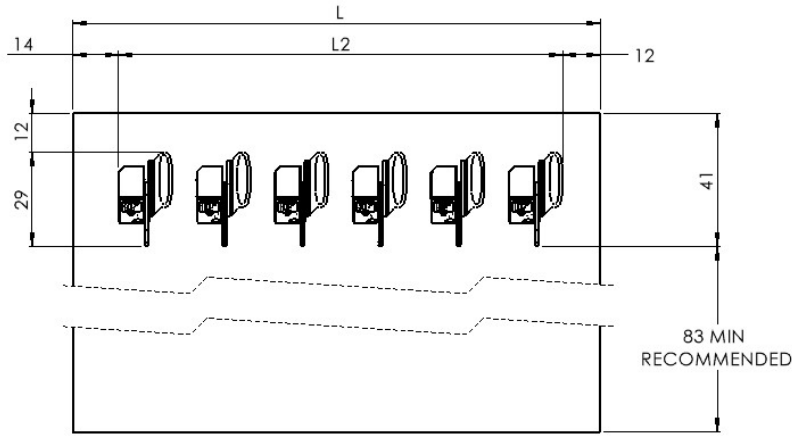

# OF DOCKS	SYSTEM LENGTH	
	"1"	"1.2"
1	42	16
2	66	40
3	90	64
4	114	88
5	138	112
6	162	136
7	186	160
8	210	184

Notes:

- All units in inches.
- Power to be stubbed in from below dock or through knockout panel.

Installation Instructions (base plate mount)

Ground Mount System Components

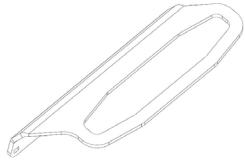

*OPTIONAL WHEEL HOLDER FOR BIKE
HEIGHT STAGGERING (PURCHASED
SEPARATELY, PART #34458)*

WHEEL HOLDER INSTALLATION HARDWARE (1 KIT PER DOCK)



CARRIAGE BOLT
QTY 2



RUBBER WASHER
QTY 2



LOCK NUT
QTY 2



STEEL WASHER
QTY 2

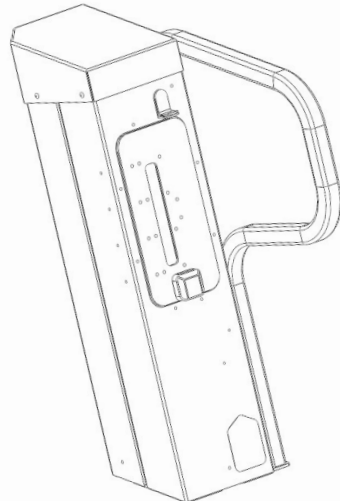

DOCK

Anchors

3/8" OR M10 Anchors
(can be purchased from
Saris Infrastructure, part
#28879) QTY 4 per Dock

TOOLS REQUIRED

- T-25 SECURITY TORX BILT
- 9/16" OR 14MM SOCKET
- 10 MM SOCKET
- RATCHET
- TORQUE WRENCH
- SMALL FLAT BLADE
SCREW-DRIVER

TOOLS REQUIRED FOR ABOVE GROUND ELECTRICAL SUPPLY

1. Remove rear panel and mark the docks for anchoring.
2. Remove the docks and install the anchors per manufacturer's instructions. Installation instructions for optional Saris concrete anchors on following pages. Anchor holes and electrical connection opening dimensions from below:

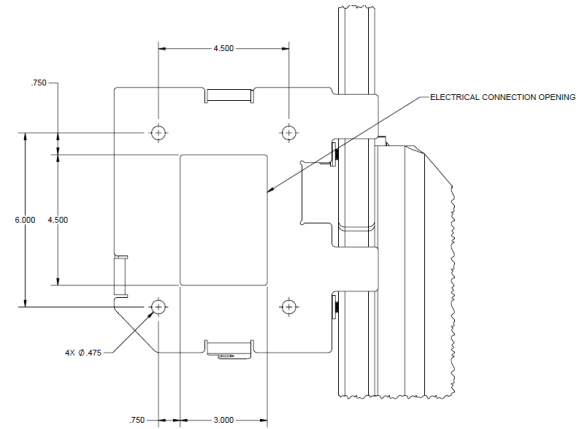

Bottom anchoring plate dimensions

3. Install four concrete anchors for each dock.
 - a. The concrete anchor (a.k.a. “drop-in anchor”) is a female anchor designed for use in solid concrete only and cannot be used in brick or block base material. The anchor size is designated by the inside diameter of the anchor. The diameter of the hole to be drilled is the same size as the outside diameter of the anchor which is ½”.

- When fastening to solid concrete with a drop-in anchor, a hole must first be drilled into the concrete using a hammer drill, as this will drill the best quality hole. Once the bit is inserted into the hammer drill, the depth of the hole to be drilled can easily be set by using the depth gauge on the drill or by wrapping the bit with tape at the required depth. We recommend a drill depth of 1-5/8" deep so that the anchor just sets down flush with the surface.

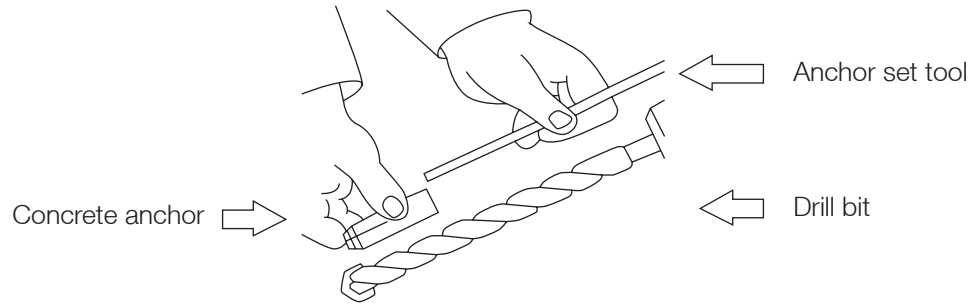

5. Before drilling, it is important that eye and ear protection are used. Make sure the hammer drill is in hammer mode and start drilling your hole. Continue drilling until the tape on the bit or the drill gauge meets the base material – this means that the required depth has been reached.

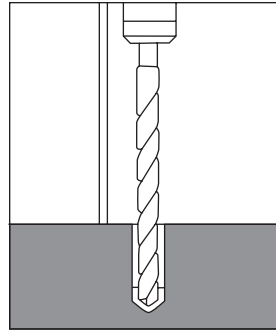

6. Before proceeding with installation, the hole must be cleaned of all concrete dust to ensure proper fastening.

Use a wire brush, vacuum, or compressed air to clean out the hole completely.

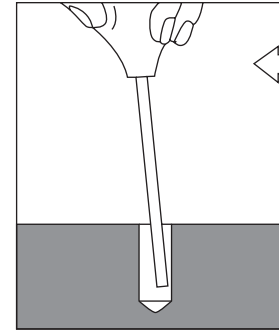

Tool to remove debris after drilling holes. Installer provides.

7. Next, insert the drop-in anchor with the open side up. Tap lightly to get the anchor flush with the base material.
8. Now, take the setting tool and insert it into the anchor. Strike the setting tool with the hammer several times until it no longer moves down. This will ensure the anchor is properly set.

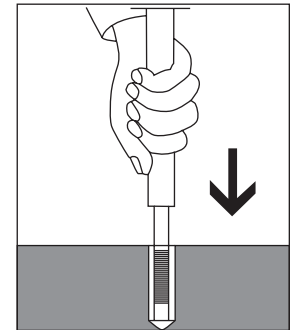

9. Reinstall the docks into position. Before securing the anchors, make sure to place conduit pieces between the docks, then tighten the anchor hardware.
10. Install wheel holders if applicable on each dock, noting the correct orientation of the wheel holder. Remove pin torx bolts and insert the carriage bolts through the wheel holder into the dock.
11. Inside of the dock, install, in order, the rubber washer, steel washer, and locknut onto the carriage bolt. Using 9/16" or 14mm socket, torque to 20-27 N-m (15-20 ft-lbs.)

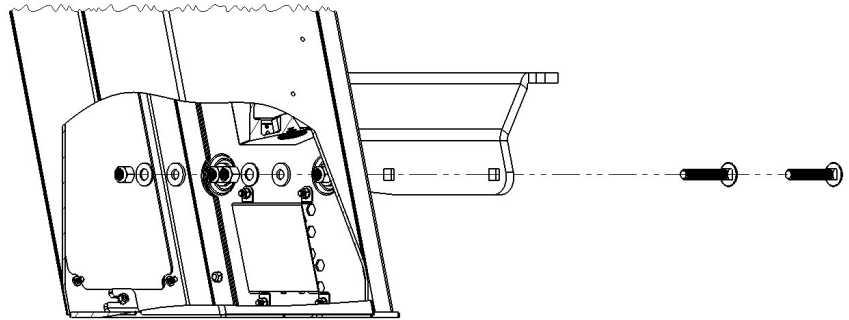
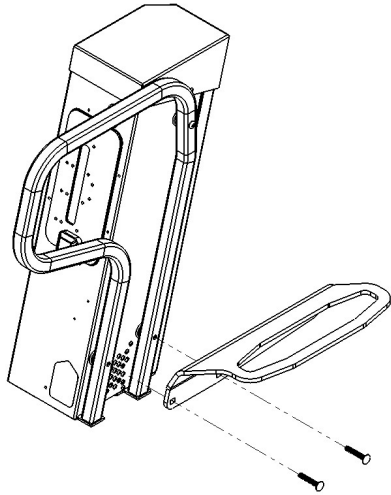

12. Ensure the wheel holder is installed in the correct orientation.

CORRECT ORIENTATION

13. Wire mains power to the junction box in the dock per legal codes. Terminal blocks are marked for Line, Neutral, and Ground connections. Power can be plumbed up from below the unit or through a knockout placed in the rear of the unit to the right of the access panel.

a. If a knockout is used, be sure to debur the edges and use a watertight connection.

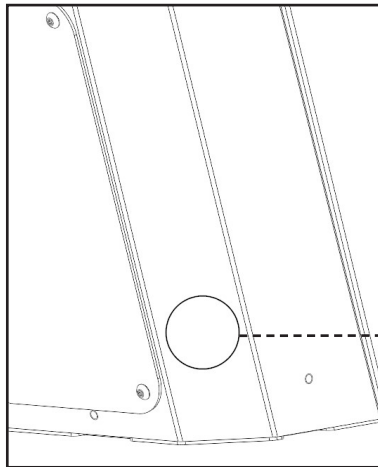

Rear view of ground mount system

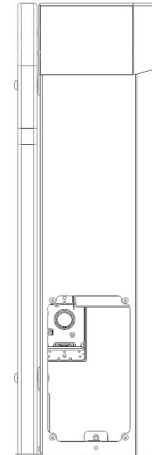

Rear view of ground mount system

Electrical Specs

Maximum Receptacle Amperage/Wattage: USA/Canada			Maximum Receptacle Amperage/Wattage: EU			Maximum Receptacle Amperage/Wattage: UK			Maximum Receptacle Amperage/Wattage: AUS/NZ		
Model #	# of Docks	Max Amps/Watts	Model #	# of Docks	Max Amps/Watts	Model #	# of Docks	Max Amps/Watts	Model #	# of Docks	Max Amps/Watts
84101320	1	20/2400	84201320	1	16/3600	84301320	1	13/2990	84401320	1	15/3450

RATINGS BY MODEL #		
Model #	Input Rating	Output rating
84101320	120V/20A ~ 60Hz	120V/20A ~ 60Hz
84201320	230-240V/16A ~ 50Hz	230-240V/16A ~ 50Hz
84301320	230-240V/13A ~ 50Hz	230-240V/13A ~ 50Hz
84401320	230-240V/15A ~ 50Hz	230-240V/15A ~ 50Hz



Standard User Instructions

1. Park bike at dock using the wheel holder.
2. Lock bicycle frame with U-lock.
3. Gain access to locker with key. Keys will typically be supplied/controlled by a property manager or similar authority.
4. Place charger into the locker and plug into the provided receptacle.
5. Route charger output cable through a port at the bottom of the door and securely close the door.
6. Plug charging cable into the charge port on the parked bicycle.

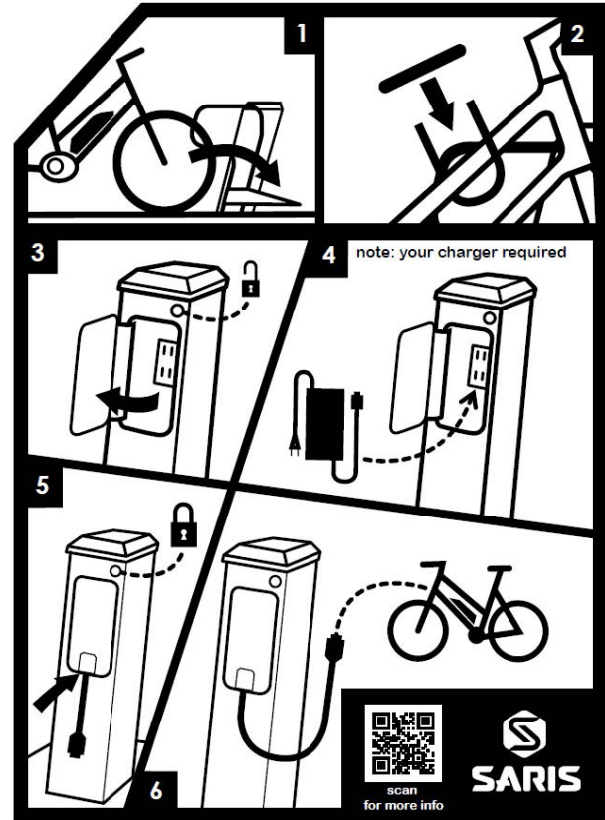

Lock Mechanism

- Locker can be secured with any standard padlock.
- Push door closed to activate latch.
- To open, rotate the upper latch to the right to release the door latch.

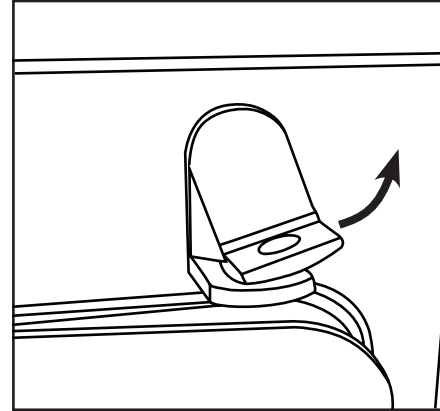
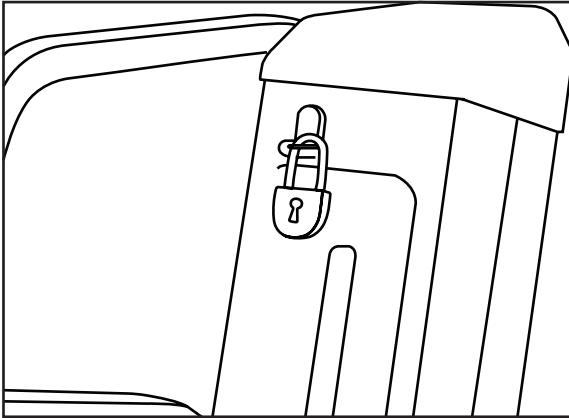

WARRANTY

WARNING: Manufacturer and seller expressly disclaim any and all liability for personal injury, property damage or loss, whether direct, indirect, or incidental, resulting from the incorrect attachment or inappropriate placement, improper use, inadequate maintenance, or neglect of this product. Placement of this product is beyond control of the manufacturer. It is the end users responsibility to place this product so as to avoid potential pedestrian or playground accidents.

WARRANTY: We warrant this product to the first consumer to be free from defect in material and workmanship for a period of one year from date of purchase. Please retain your sales slip for your records. Any product or part thereof found to be defective within that period will be replaced without charge provided that: (1) the product was not misused; (2) no alterations or modifications were made; (3) its failure resulted from a defect in material or workmanship and not from normal wear expected in the use of the product; (4) the product or part is delivered, freight prepaid, to Saris Products. Manufacturer's only obligation shall be to replace such products or parts proved to be defective.

Saris Infrastructure 5253 Verona Road Madison, WI 53711 (800)783-7257 www.sarisinfrastructure.com