

**SDCI**

**Director's Rule 6-2020**

**SDOT**

**Director's Rule 1-2020**

<b>Applicant:</b>  City of Seattle Department of Construction and Inspections, and Seattle Department of Transportation	<b>Page:</b>  1 of 8	<b>Supersedes:</b>  NA
	<b>Publication:</b>  2/24/2020	<b>Effective:</b>  10/22/2020
<b>Subject:</b>  Bicycle Parking Guidelines and Application of Bicycle Parking Development Standards	<b>Code and Section Reference:</b>  SMC 23.54.015.K	
	<b>Type of Rule:</b>  Code Interpretation and Procedural Rule	
	<b>Ordinance Authority:</b>  SMC 3.06.040	
<b>Index:</b>  Land Use Code/Technical Standards and Procedural Requirements	<b>Approved</b>	<b>Date</b>
	(signature on file) <b>Nathan Torgelson, Director</b>	<u>10/22/2020</u>
	(signature on file) <b>Sam Zimbabwe, Director</b>	<u>10/21/2020</u>

## **INTRODUCTION**

The purpose of this rule is to inform the design of bicycle parking facilities by clarifying the performance standards for required bicycle parking in SMC 23.54.015.K, Seattle Department of Transportation (SDOT) Bicycle Parking Guidelines, and industry best practices.

Seattle's Department of Construction and Inspections (SDCI) reviews development projects for compliance with Land Use Code requirements for bicycle parking on private property. SDOT, in consultation with SDCI, regulates short-term bicycle parking proposed in public rights-of-way.

SMC subsection 23.54.015.K requires bicycle parking to be highly visible, safe, and convenient, with an emphasis on user convenience and theft deterrence. This Director's Rule is used to evaluate compliance of proposed bicycle parking specifications with the Land Use Code (Title 23) bicycle parking requirements on private property. SDOT's Seattle Bicycle Parking Guidelines are used to locate and design short-term bicycle parking in the right-of-way and provide qualitative guidance for both short-term and long-term bike parking design and installation, whether located in the right-of-way or on private property. In case of conflicts, the provisions of subsection 23.54.015.K and this Joint Director's Rule shall take precedence over the SDOT Bicycle Parking Guidelines, dated October 2020, that are found attached to this rule.

Projects that require a Transportation Management Program (TMP) may need to provide bicycle parking in excess of the minimum quantities specified in the Code to facilitate additional bicycle trips and mitigate the number of motor vehicle trips associated with development. Property owners and their representatives responsible for implementing terms of their development's TMP should consult this Rule for details on installing bicycle parking per City requirements and guidance.

## **RULE**

### **1. Weather Protection**

Weather protection for required long-term bicycle parking shall be designed to keep bicycles dry and prevent the effects of long-term weather exposure such as rust and hardware degradation.

Weather protection can take the form of a fully enclosed structure, a partially enclosed structure, awnings, eaves, or a locker or similar product.

#### **a. Full Enclosure**

Full enclosure means a permanent weatherproof structure surrounded by walls or doors on all sides and covered with a roof. Bicycle rooms, cages within an enclosed structure, closets, lockers, garages, sheds or another fully enclosed structure or portion thereof shall:

- Have a secure entry door;
- Be sized according to standards in Section 2 of this Rule to accommodate the required number of bicycles;
- If the structure is shared, have bicycle racks that allow each bicycle to be individually locked; and

- Maintain at least 7 feet of vertical clearance between the ground and ceiling (or any elevated obstruction) when the design of the enclosure is meant for a person to enter under the weather protection. One example of a fully enclosed bicycle parking space that can have less than 7 feet of vertical clearance is a closet accessed by exterior door.

**b. Partial Enclosure**

Partial enclosure means a permanent structure or portion of a structure surrounded by or abutting walls or other barriers on one or more sides with an impervious barrier overhead. For example, a covered, freestanding structure that abuts a wall or similar barrier on one or more sides may constitute a partially enclosed structure. In lieu of full enclosure, SDCI's Director may permit a partially enclosed structure or portion thereof, or partially enclosed overhead weather protection, if otherwise allowed by SMC Title 23 and when:

- all bicycle parking spaces using it meet dimensional standards for the rack type proposed;
- bicycle access to it meets dimensional standards;
- bicycle racks or fixtures are provided that allow each bicycle to be individually locked;
- the overhead portion extends beyond the required bicycle parking space footprint dimensions at least 18 inches on all exposed sides (except as noted below); and
- vertical clearance of at least 7 feet but no more than 10 feet between the ground and ceiling (or any elevated obstruction), except that, on a case-by-case basis:
  - partially enclosed, freestanding structures with bicycle-parking fixtures meeting all manufacturer's specifications may be permitted to have less than 18 inches of overhang on all exposed sides and less than 7 feet of interior vertical clearance.
  - freestanding partial enclosures with no less than 5 feet of internal vertical clearance may be permitted.
- Where wall-mounted bicycle-parking fixtures allow bicycles to be locked in a flush-mounted position (parallel to the wall surface), an awning with a minimum depth of 3 feet from the wall surface may be used to provide weather protection. This kind of awning also should extend at least one foot beyond the mounted bicycle's width on both ends.

A combination of the partial and full enclosure methods is allowed subject to all criteria outlined above.

**c. Lockers**

Bicycle lockers may be used to provide weather-protected, secure bicycle parking in outdoor locations.

**2. Standards**

**Standard Bicycle Dimensions**

The dimensions for a standard bicycle are 2 feet wide by 6 feet long by 40 inches in height.

### **Bicycle Parking Space Dimensions**

Required bicycle parking spaces must meet standards described below, unless otherwise specified by the bicycle parking hardware manufacturer and approved by SDCI. Providing some bicycle parking spaces that can fit non-standard bicycles (such as cargo, family, or adaptive bikes that may be 7-9 feet long and 3-4 feet wide) is encouraged.

**Horizontal Rack - Single Space:** 2 feet wide by 6 feet long by 40 inches in height.

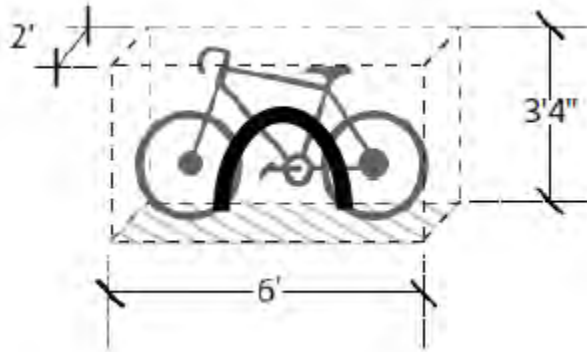

**Horizontal Rack – Side-by-Side Spaces:** 18 inches wide by 6 feet long by 40 inches in height.

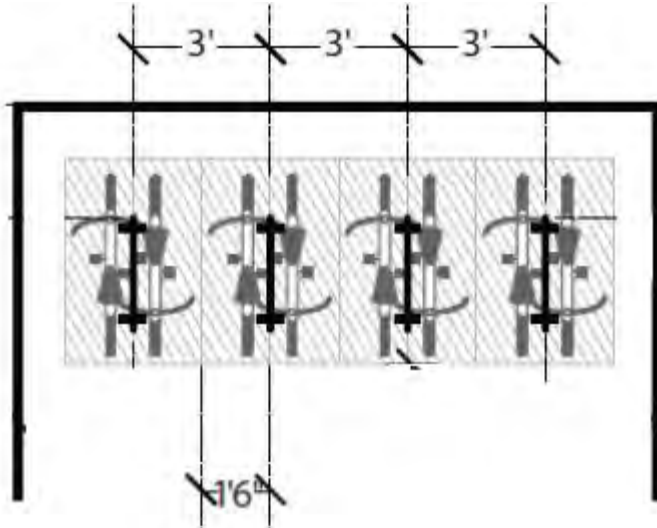

**Vertical Rack – Single Space:** 2 feet wide by 40 inches deep by 7 feet in height.

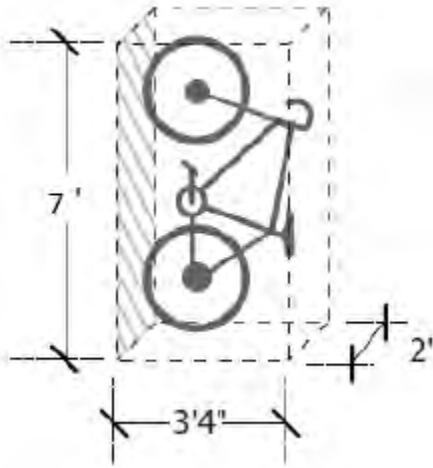

**Vertical Rack – Multiple (Alternating):** 16 inches wide by 40 inches deep by 87 inches in height.

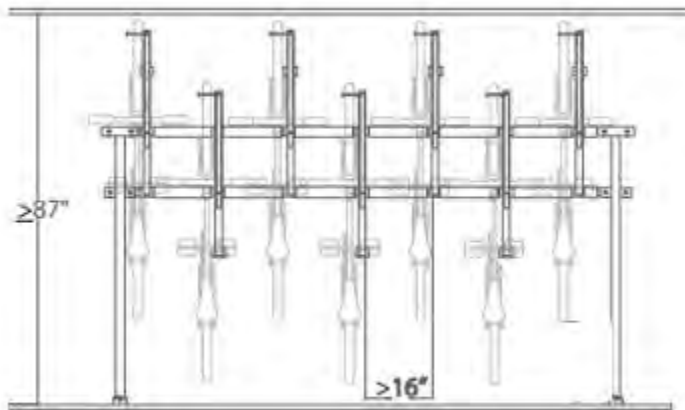

**Bicycle Locker – Single**: minimum access door of 2 feet wide with internal dimensions of 6 feet long and 4 feet in height.

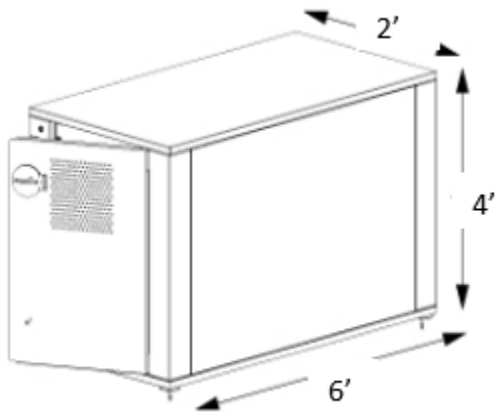

**Bicycle Locker - Double**: minimum access door of 2 feet wide with minimum internal dimensions of 2 feet-6 inches wide by 6 feet-6 inches long (when the locker divides the bicycle parking space into two triangular shaped spaces) by 4 feet in height.

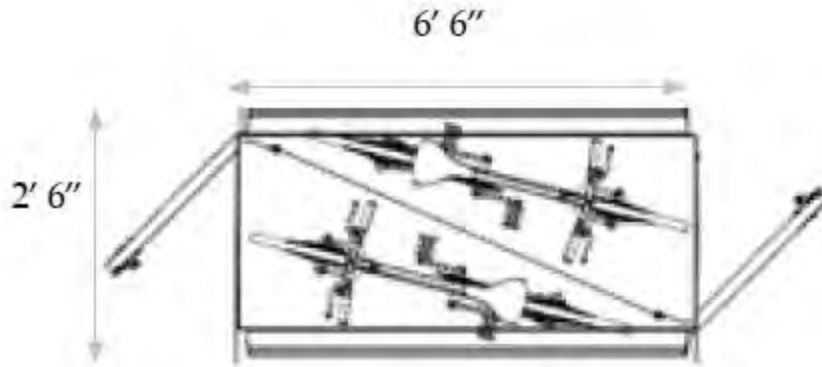

**Clearance – Horizontal rack clearance from vertical obstructions:**

When parallel to a wall and providing two parking spaces, a horizontal rack must be at least 3 feet away from any vertical obstruction. If less than 3 feet are provided, such placement satisfies only one required bicycle parking space (on the side opposite the vertical obstruction). When perpendicular to a wall, the rack must be at least 2 feet away from the vertical obstruction.

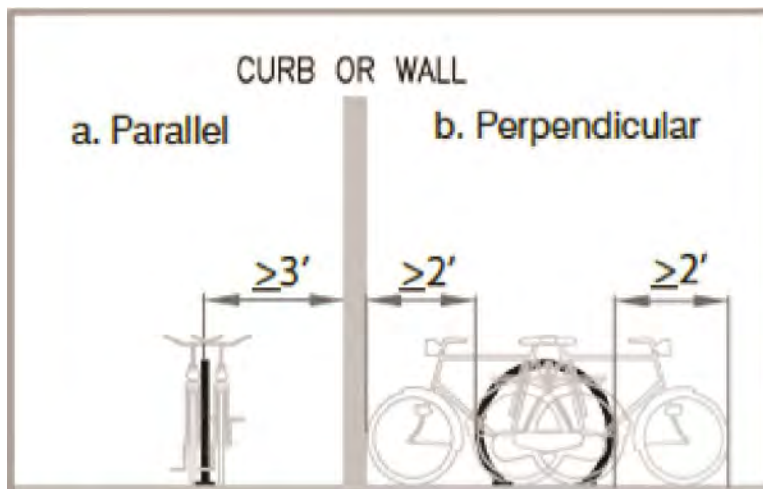

**Access aisle dimensions:**

The minimum access aisle width is 3 feet. Required bicycle parking provided in a private garage associated with only one principal dwelling unit need not provide a separate bicycle parking access aisle. When manufacturer's specifications require a wider aisle width, such as for double decker bicycle parking, the project must comply with manufacturer's specifications.

**Runnels:**

These sloped channels may be provided alongside stairs for wheeling bicycles rather than requiring cyclists to carry bicycles up or down stairs.

### **3. Visibility and Wayfinding**

**Directional Signage**

Short-term: When short-term bicycle parking is not located in the street right-of-way abutting the associated use or between the principal structure and the street right-of-way, signage directing bicyclists to short-term bicycle parking must be installed at the primary entrance for the associated use.

### **4. Security**

Each required bicycle parking space must provide an associated rack or bicycle-parking fixture to which the bicycle can be locked. Each rack or fixture must allow locking of bicycle frames and one wheel with a U-lock or equivalent. Each rack must be mounted securely to a flat surface (horizontal or vertical) according to hardware specifications and manufacturer's installation

instructions. Required bicycle parking provided in a secure, individual, private garage associated with only one principal dwelling unit need not provide a rack or fixture to which a bicycle can be locked.

When required long-term bicycle parking spaces are provided in a partial enclosure, the long-term bicycle parking associated with it must be screened from direct street view.

## **5. Plan Requirements**

The following bicycle parking information must be included in plans as part of the master use and construction permit applications:

- 1) Calculation for quantity of bicycle parking spaces required and proposed
- 2) Bicycle parking location and space dimensions
- 3) Type of rack or fixture (hardware) and mounting proposed
- 4) Vertical clearance dimensions
- 5) Dimensions for clearance from wall or other vertical obstruction
- 6) Dimensions for separation between racks
- 7) Note or verification of lighting
- 8) Dimensioned bicycle parking access route
- 9) Manufacturer's installation specifications for mounting, and where applicable, clearance and aisle width (if proposing alternate standards to Director)
- 10) Where required, sign detail and sign location for wayfinding.



Seattle Department of Transportation

# SEATTLE BICYCLE PARKING GUIDELINES



October 2020



**Seattle**  
Department of  
Transportation

# CONTENTS

1. Introduction.....	3
2. Short Term Bicycle Parking.....	6
3. Long Term Bicycle Parking.....	15
4. Bicycle Rack Examples and Specifications .....	20
Appendices.....	23
A - Additional Resources	
B - City of Seattle Bike Standard Corral Plans and Elevations	
C - Short-Term Bicycle Parking Layout	
D - Long-Term Bicycle Parking Layout Examples	
E - Bike Rack Materials and Coatings from APBP	
F - Bike Rack Installation from APBP	



*Bicycle Racks at Husky Stadium (Photo: MIG|SvR)*



# 1. INTRODUCTION

## OVERVIEW AND PURPOSE

Safe and secure bicycle parking is a key amenity that encourages people to bike to work, school, or to run errands. Bicycling is good for one's health, it's an affordable transportation option, and it's environmentally friendly. To encourage ridership there is a need for convenient short-term (less than 4 hours) and long-term (4 hours or more) bicycle parking facilities; after all, there can only be as many people biking as there are safe places to leave a bike. There are many benefits to providing bicycle parking, including:

- Bike parking facilities legitimize biking as an important mode of transportation that reduces the number of motor vehicles on the road. Bike parking requires less space than motor vehicle parking and in many situations allows users to park closer to their destinations.
- Convenient bike racks provide an amenity for customers, and businesses benefit by making it more convenient for people riding bicycles to patronize their establishment.
- Well organized and planned bike parking maintains pedestrian access, prevents clutter and minimizes impacts on adjacent uses.



On-street bicycle parking corral (Photo: SDOT)

This guide centralizes information for providing bicycle parking for both short and long-term use. It addresses public and private bicycle parking requirements, design standards, optional guidance, and practical information such as how to request a bicycle rack in the public right-of-way (ROW). These guidelines include key considerations, best practices, and resources for selecting and installing bike racks for public and private use. **This guide is both a resource for new development that is required to provide bicycle parking and for property and business owners who would like to add bike parking in or near existing buildings and in the right of way.**

## USING THIS GUIDE

Planning for bike parking should begin by understanding the needs of the users. Users may include business customers, residents, employees, and facility visitors. Types of bikes, length of visit, expected route to parking from nearest bike route

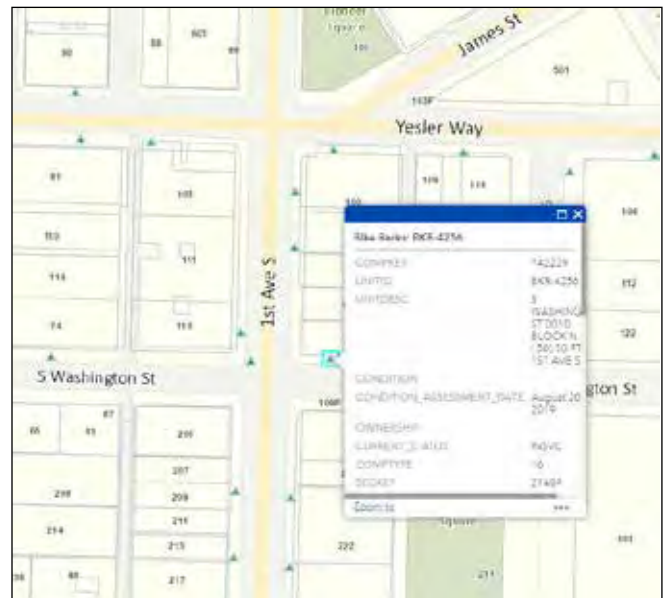

Screen shot from the interactive SDOT Online Bike Rack GIS Map (see Appendix A for link)

or facility and desired/expected volume are all considerations. This guide divides bicycle parking into short-term and long-term parking.

- Chapter 2 covers short-term parking with guidelines on rack types, placement, permitting process, and how to request a bike rack.
- Chapter 3 provides information on long-term parking with required standards and recommendations on how to create exceptional long-term parking facilities that appeal to residents, employees and other bicycle commuters.
- Chapter 4 includes standard and custom bike rack guidelines, including rack and mounting hardware specifications.
- The Appendices compile additional useful information for both cyclists and those interested in offering bike parking.

## BACKGROUND INFORMATION

### Guiding Documents

The following are the primary documents referenced in the development of these guidelines. See Appendix A for links.

- Seattle Streets Illustrated (<https://streetsillustrated.seattle.gov/>)

- Association of Pedestrian and Bicycle Professionals (APBP) Bicycle Parking Guidelines (2nd edition) [www.apbp.org](http://www.apbp.org)
- San Francisco Municipal Transportation Agency Bicycle Parking: [Standards, Guidelines, Recommendation](#) (2015)
- Portland Bicycle Parking Code Updates: [www.portlandoregon.gov/transportation/70439](http://www.portlandoregon.gov/transportation/70439) (2020)



*Sidewalk racks on Lincoln Way (Photo: MIG|SvR)*



*Short-term sheltered bike racks next to a long-term secure parking area at UW (Photo: MIG|SvR)*

## BICYCLE PARKING CLASSIFICATION

- Short-term bicycle parking is for bicycles parked less than 4 hours in locations that are easily accessible.
- Long-term bicycle parking is for bicycles parked 4 or more hours and requires more secure parking.

FIGURE 1-1: BICYCLE PARKING CLASSIFICATION

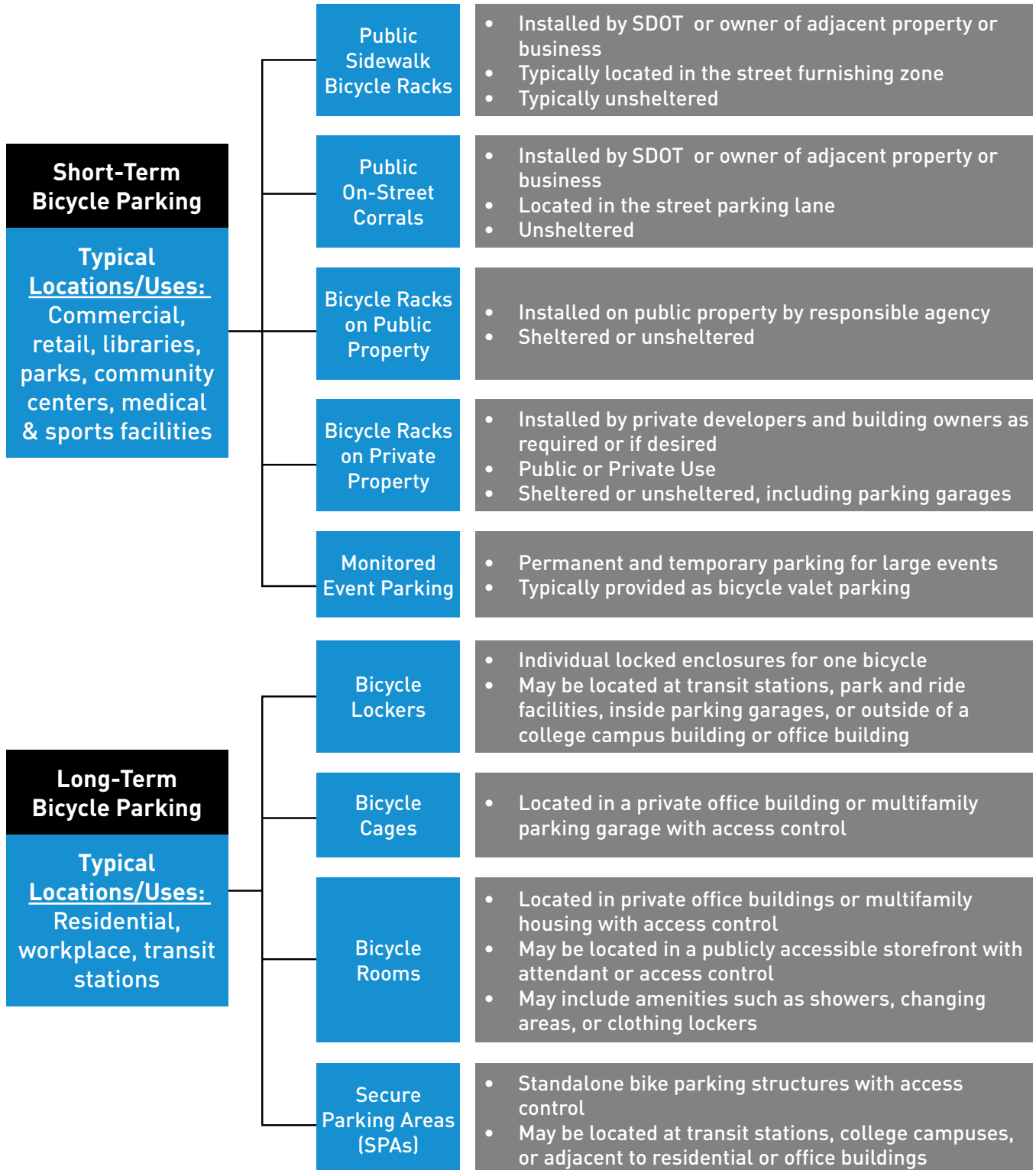



## 2. SHORT-TERM BICYCLE PARKING

### INTRODUCTION

Short-term bicycle parking accommodates bikes parked less than four hours in locations that are easily accessible, such as sidewalks, bicycle corrals located in the street parking lane, parks and other public facilities, and on private property for visitors, customers and residents. Short-term bicycle parking encourages people to bike by offering convenient parking options. Bicycle parking can provide parking for more visitors and customers as bike racks require less space than motor vehicle parking. Designating locations for bicycle parking in the right of way (ROW) prevents visual and physical clutter of unplanned parking and avoids bicycle parking that might block pedestrian access or damage trees.

### OVERVIEW OF SHORT-TERM BICYCLE PARKING TYPES

#### Public Sidewalk Bicycle Parking

- Racks are typically installed by Seattle Department of Transportation (SDOT).
- Custom or non-standard racks can be installed by a private party
- Typically located in the street furnishing zone
- Typically unsheltered



*Inverted U sidewalk rack on 2nd Ave (Photo: MIG|SvR)*

#### Public On-Street Bicycle Parking Corrals

- Installed by SDOT or as part of new developments
- Located in the street parking lane
- Can be sited near crosswalks where vehicle parking is prohibited, or mid block
- Typically unsheltered

#### Public Bicycle Parking on Public Property

- Installed on public property by responsible agency (e.g. Seattle Public Library, Seattle Parks and Recreation, Seattle School District, King County Metro, etc.)
- Sheltered or unsheltered

#### Private Property Bicycle Parking

- Installed by private developers and building owners as required or desired. These racks are located at commercial frontages.
- Public or private use
- Sheltered or unsheltered

#### Monitored Event Parking

- Monitored permanent and temporary bicycle parking at event venues such as sport facilities, theaters, and large public events like festivals and races. This could include valet bike parking.



*Rail type sidewalk racks on 1st Ave (Photo: SDOT)*

## SHORT-TERM BICYCLE PARKING DESCRIPTIONS

### Public Sidewalk Bicycle Parking

#### Standard Bicycle Racks:

- The SDOT Bicycle Spot Improvement Program installs bicycle racks to encourage bicycling for short trips and errands. The racks provide safe and convenient bicycle parking.
- Standard Bicycle Racks are installed by SDOT at the request of businesses or property owners, managers, and citizens. Bicycle Program staff work with representatives from interested businesses to explain the program, answer questions and select locations for racks.
- Public sidewalk bicycle racks remain the property of SDOT and SDOT assumes responsibility for standard racks, but not for parked bicycles.
- See Chapter 4 Bicycle Rack Examples and Specifications for more details

#### Custom Sidewalk Bicycle Racks:

- Custom bicycle racks require a street use permit or a partnership with SDOT to install in a neighborhood or district.
- Custom bicycle racks are typically maintained by the applicant. If applicants transfer racks to SDOT for maintenance, there is no guarantee of custom rack replacement in the event the rack is damaged.



*On-street bicycle corral on NW Vernon PL (Photo: Bicycle Security Advocates)*

- See Chapter 4 Bicycle Rack Examples and Specifications for more details

### Public On-Street Bicycle Parking Corrals

Corrals or on-street bicycle parking can accommodate many more bicyclists than a typical bicycle rack. Pedestrians also benefit from the reduced clutter along increasingly-encumbered sidewalks. Installing bike corrals near intersections or driveways can also protect sight distance clearances.

- On-Street bicycle corrals are placed in the street parking lane
- Can accommodate approximately 6 to 12 bicycles for each motor vehicle on-street parking space
- Corrals are often located near the intersection where motor vehicle parking is not allowed due to sightlines
- Bike corrals provide increased visibility for bicycle parking
- Bike corrals may provide opportunities for the incorporation of public art or placemaking
- Bikes parked in corrals in the parking lane allow more room for pedestrians and furnishings on the sidewalk

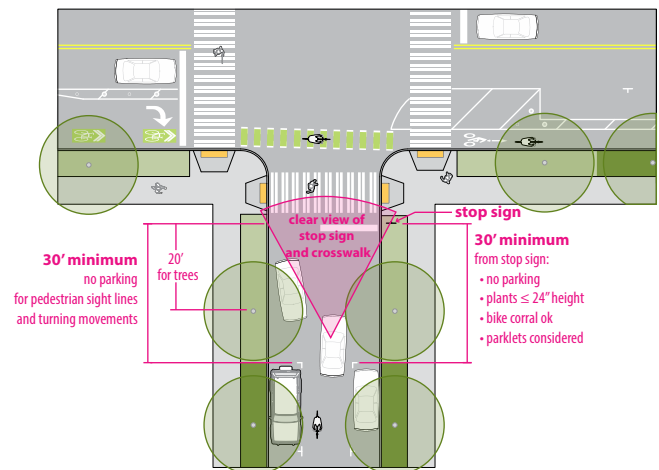

*Horizontal clearances from a stop sign (Image: Seattle Right-of-Way Improvements Manual)*



*On-street bicycle corral installation at Capitol Hill Light Rail Station (Photo: SDOT)*



*Bike parking at Lake Union Park (Photo: MIG/SvR)*

SDOT will consider installing on-street bicycle corrals upon receiving a request. Converting a motor vehicle parking space to on-street bike parking is warranted in locations where bicycle parking demand is high and sidewalks are constrained—for example, outside of restaurants with sidewalk cafés or in neighborhoods with narrow sidewalks flanked with tree pits and assorted street furniture.

- See Chapter 4 for more details

### **Public Bicycle Racks on Public Property**

- Bicycle racks provide short-term parking at public facilities such as schools, libraries, parks and transit stations.
- These racks are either designed as part of new facility, a facility upgrade or as a retrofit.
- SDOT may provide bike racks to Seattle public agencies, such as the Seattle Public Library, Seattle School District and Seattle Parks and Recreation for retrofit projects. SDOT supplied racks are then installed by the agency receiving the racks.

### **Private Property Bicycle Rack**

- Racks offer short-term bicycle parking at stores, businesses, offices, institutions, and multi-family residences.
- Location should be highly visible, safe, well-lit and accessible, emphasizing user convenience and deterrence of theft.



*Private bicycle parking at REI (Photo: MIG/SvR)*

- When possible, it's encouraged that bike parking facilities be shared by more than one business.
- Racks provided on public property by a developer may be counted toward bicycle parking requirements for their project.

### **Monitored Event Bicycle Parking**



*Bike parking at the Amazon Campus (Photo: MIG/SvR)*





*Festival bike parking at Ballard Street Fair (Photo: SDOT)*

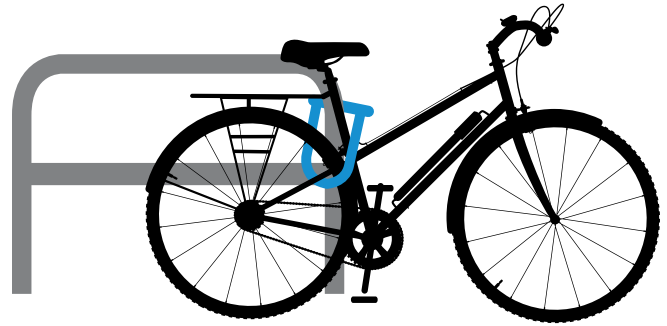

*Make sure to lock up above cross bar*

- Short-term parking, whether permanent or temporary, supports bicycling as an option to attendees of sporting events, stadiums, festivals, fairs, etc.
- Providing bicycle parking at large events helps ease traffic congestion at the start and finish of these events
- Bike Works is a Seattle area organization that provides event parking for a fee.

### **Bike Share Parking**

- Bike share parking spaces cannot be counted towards a developer's required amount of short-term bicycle parking, but considering and providing publicly available spaces for shared bikes and other micromobility devices is encouraged.

## **REQUESTING OR PERMITTING BICYCLE RACKS IN THE ROW**

### **Sidewalk Bicycle Rack or On-Street Bicycle Corral Request**

- Due to budget limitations SDOT's Request based bicycle rack program is on pause through at least the end of 2020.
- Send requests to [walkandbike@seattle.gov](mailto:walkandbike@seattle.gov) or (206) 684-7583
- Please include the following items:
  - Name of the requestor and business
  - Address of the business
  - Location for rack if different

- Name of the requester (or the name of the business owner)
- Phone number of requester (or that of the business owner)
- Email of requester (or business owner)
- Type of rack requested (either a sidewalk rack or an on-street corral)
- An estimation of the quantity needed. Ideas for placement are helpful.

- SDOT staff will contact the requester to coordinate installation of standard rack

### **Bicycle Rack Permit Process**

- The applicant must show the location of bike racks in relation to building entries, utilities, trees, furnishings, etc. in a landscape plan, Street Improvement Plan, site plan, or similar document. SDOT will review clearances shown in the plan.
- Custom bike racks as part of a development permit require a Street Use Permit while standard racks do not.
- If a custom rack meets SDOT's minimum requirements (See Chapter 4), SDOT may take ownership of rack immediately after installation if desired by owner.
- A Permit must be acquired from SDOT's Street Use Division for non-standard bike racks and corrals.
  - Include the following with the permit application form:
    - \*Site Plan (11x17 paper size preferred)

- Note the following on the site plan:
  - Proposed location of bike rack. See the Right-of-Way Improvements Manual (ROWIM) for standard clearance from bicycle parking. These clearances are also listed in the following section on short term bike parking requirements.
  - Street name and building address
- Include bike rack product information:
  - Note type and model of bike rack.
  - If non-standard bike rack, submit the manufacturer’s cut sheet, including model, dimensions, material and finish, and installation method and type.
  - For bike rack see customization, in Chapter 4 Bicycle Rack Examples and Specifications

## SHORT-TERM BICYCLE PARKING DESCRIPTION

### Required Number of Bicycle Racks

- See Seattle Municipal Code 23.54.015, subsection K, for Required Bicycle Parking. Current code is available online at [https://library.municode.com/wa/seattle/codes/municipal\\_code?nodet=TIT23LAUSCO](https://library.municode.com/wa/seattle/codes/municipal_code?nodet=TIT23LAUSCO)

## General Bicycle Rack Location and Layout

The Seattle Streets Illustrated Right-of-Way Improvements Manual provides current standard clearances from bicycle parking and other related clearances in the ROW. See Appendix C for short-term bicycle parking layout and clearances.

- Standard bicycle dimensions are 2-feet wide by 6-feet long. Racks and their placement must accommodate this space at a minimum.
- It is preferable to locate racks on a fairly level surface. When locating racks on a steeper slope, align racks perpendicular to the slope or level rack as possible with spacers / washers under the footings.
- If an applicant cannot meet the minimum clearances they may seek a deviation on a case by case basis from SDOT per section 4.6 in Streets Illustrated.
- Install racks as close to, without being directly in front of, the main pedestrian entrance(s) of a building or site as possible, 25 to 50 feet preferred.
- Provide required clearance from other street features, furniture, and utilities per Streets Illustrated.
- At high volume locations, provide for the widest variety of bicycles (family bikes and mobility trikes) and allow for greater clearances than the standards.

TABLE 2-1: STREETS ILLUSTRATED BICYCLE PARKING CLEARANCES

From	To	Standard Clearance
Bicycle Parking	Curb when adjacent to parking	Parallel: 4' Angled: 4.5' Perpendicular: 5.5'
	Curb when adjacent to vehicle travel lane	Parallel: 3' Angled: 3.5' Perpendicular: 4.5'
	Street trees, street furniture, and adjacent bicycle racks	Street Trees: 5' Street Furniture, if Angled: 2.5' Street Furniture, if Parallel: 3' From Edge of Rack to adjacent Rack, if Angled or Perpendicular: 3' From Edge of Rack to adjacent Rack, if Parallel: 5'
	Fire hydrants and utility vaults	5'

## Sidewalk Bicycle Rack Location and Layout

SDOT will review and approve all proposed bicycle racks locations in the ROW. Location requirements for public sidewalk bicycle racks and public on-site bicycle racks include:

- Are to be installed in public space, usually on a sidewalk. When installed on a sidewalk, racks must not encroach within a 2' lateral clearance from either side of the pedestrian clear zone. Larger clearances may be required in downtown and heavy pedestrian areas. Check with your plan reviewer to confirm if larger clearance requirements apply to your project.
- Racks can be installed in bus stops or loading zones only if they do not interfere with boarding or loading patterns and there are no alternative locations. See King County Metro Transit Facility Guidelines for example layouts.

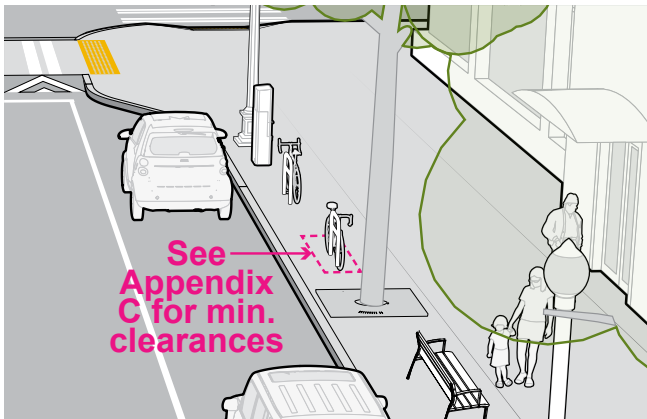

*Horizontal Clearances (Image: Streets Illustrated)*



*Bike corral on University Way NE (Photo: SDOT)*



*Private bicycle parking (Image: Sportworks)*

## Public On-Street Bicycle Corral Location and Layout

- The size and capacity of the bicycle corral is based on available space as well as demand for bicycle parking.
- On-street bike corrals must be oriented so that bicyclists can safely enter and exit without conflicting with motor vehicles or pedestrians.
- Placing bike corrals in no-parking areas near intersections allows them to function like curb extensions, providing visibility and protected space for crossing pedestrians as well as bicyclists entering and leaving the corral.
- Pavement markings, bollards or wheel stops must be used to define and protect the corral.
- Avoid locating bike corrals in areas where public utilities are located or where curbsides are prone to flooding.

## Private Property Bicycle Parking Location and Layout

- Wayfinding is required if the bicycle parking location is not visible from the site or building entrance.
- Provide signage to clarify if bicycle parking is for customer use only.
- At high volume locations, consider the widest variety of bicycles (family bikes and mobility trikes) and allow for greater clearances.





*Bike shelter at Woodland Park Zoo (Photo: MIG/SvR)*

Required short-term bicycle parking may be provided within the interior of an applicable land use. SDOT encourages the bicycle parking to be placed on the ground floor, near the entrance to the land use. The bicycle parking must allow for users to lock the bicycle frame and one wheel with a u-lock, and at least one bicycle rack is recommended to be publicly available 24 hours per day within 25 to 50 feet of the entrance.

### **MONITORED EVENT BIKE PARKING**

- Monitored event parking or valet bicycle parking offers a way to securely park large numbers of bicycles at events. It typically has staff or volunteers keeping watch over a temporary bicycle corral.
- Monitored event bicycle parking may be provided by an event venue or event producer under the following situations:
- A theater or spectator sports facility may reduce short-term bicycle parking requirements with attended event parking as authorized by SDOT through a Transportation Management Program.
- Other event venue types may meet short-term bicycle parking requirements by specifying a clear spatial dedication in the Street Improvement Plan or Building Site Plan, and specifying a clear and cogent plan and commitment to providing the monitored event parking.



*Sidewalk bike rack on 3rd Ave (Photo: Alta Planning + Design)*



*Bike corral on Fremont Ave (Photo: MIG/SvR)*



*On-street bicycle parking at Pike Place Market (Photo: SDOT)*

- Monitored event bicycle parking shall not be used to meet the minimum short-term bicycle parking requirements for any other land uses other than event venues.

## BIKE SHARE AND MICROMOBILITY DEVICE PARKING

- SDOT encourages that new developments include an outdoor “landing pad” reserved for dockless bikes or other micromobility devices near the location of other short term bicycle parking, especially in downtown or other locations with heavy bike share demand.
- This type of space would prevent bikes from being left either in the sidewalk zone where they might obstruct pedestrians, or within landscaped areas where damage could occur.
- Micromobility device parking should be located near planned short-term bicycle parking or an entrance and identified with signage. One simple solution is a 6' x 10' painted box on the ground with a bike symbol.

## SHORT-TERM BIKE PARKING ENHANCEMENTS

- Customization options
  - Weather protection using building awnings, overhangs and shelters. Consult Streets Illustrated for information about structures in the right of way.
  - Electrical outlets for charging of electric bicycles.
  - Security cameras pointed toward racks
  - For passive surveillance, locate bike parking in front of business windows and in high traffic areas to allow bicyclists and others to keep an eye on the bikes.
  - Signage that encourages bicyclists to properly lock-up and to register their bicycles on an independent bicycle registry.

- Designing for family or cargo bikes:
  - These bikes range from 7 to 9 feet in length and may have wide boxes on front/rear - plan for additional space. Destinations such as schools, daycares, grocery stores, and apartment buildings with family-sized units should install racks with greater clearances.

## MAINTENANCE OF BICYCLE RACKS & CORRALS IN THE ROW & PUBLIC PROPERTY

- SDOT may assume ownership and maintenance of bicycle racks and corrals located in the ROW once they are installed.
- SDOT may take ownership of permitted custom racks that meet their minimum requirements after the initial street use application and first year. See Chapter 4.
- Racks located on public property will be maintained by the associated City department or institution (Library, Parks, Schools, etc.).
- Use the City’s “Find It, Fix It” smartphone app or call the City’s [Customer Service Bureau](#) at 206- 684-2489, TTY: 7-1-1 to report damaged bike racks in the ROW.



## GOOD SHORT-TERM BICYCLE PARKING EXAMPLES



*On-street bike corral near an intersection in Ballard (Photo: Alta Planning + Design)*



*Racks are protected under building cover at Swedish First Hill (Photo: Alta Planning + Design)*



*Racks under a shelter with lighting & repair station at UW (Photo: MIG/SvR)*



*Multiple public racks at a high demand location at the University Stadium Light Rail Station (Photo: MIG/SvR)*



*Rail type rack with space for a cargo bike on Greenwood Ave N (Photo: MIG/SvR)*



*Bicycle parking corral with spaces for bike share and private bicycles (Photo: SDOT)*

## NOT SO GOOD SHORT-TERM BICYCLE PARKING EXAMPLES



*Rack does not provide 2 points of support or place to lock to frame (Photo: MIG/SvR)*



*Non-intuitive rack does not provide 2 points of support (Photo: Alta Planning + Design)*



*Rack does not provide 2 points of support (Photo: MIG/SvR)*



*Rack does not allow use of a u-lock (Photo: Alta Planning + Design)*



*Rack is not intuitive (Photo: MIG/SvR)*



*Inadequate bike parking provided (Photo: SDOT)*

# 3. LONG-TERM BICYCLE PARKING

## INTRODUCTION

When bicycles are parked for more than 4 hours, there are additional security needs to ensure that the bikes are safe from theft and vandalism and sheltered from weather over prolonged periods of time. This is especially important for building residents, employees, commuters or other individuals who require overnight or workday storage. Users of more valuable bicycles, such as e-bikes, may opt for more secure bicycle parking even if the bike is parked for less than 4 hours. Typically, secure long-term bicycle parking is located in a building bike room, shared cage in a garage, or in a standalone enclosure such as a locker or structure. Any bicycle parking should still be in a convenient, visible, and safe location to encourage use. New buildings are required to provide long term parking per SMC 23.54.015 Table D. Building and business owners may voluntarily retrofit to meet these criteria.

## OVERVIEW OF LONG-TERM BICYCLE PARKING TYPES

### Bicycle Lockers

- Box enclosures which can hold one individual bicycle that may be keyed or accessed by a smart card (e-lockers)
- Can be found at transit centers, parking garages, or inside or outside of buildings
- Shared bicycle racks placed in a caged enclosure in a parking garage
- Typically located in a private office building or multifamily residential building with keyed access

### Bicycle Rooms & Bicycle Cages

- Indoor room with shared bicycle racks
- Typically located in a storefront or ground floor location of an office building or multifamily residential building

### Secure Parking Area (SPAs)

- Shared racks within a standalone structure or building extension.
- Can be found at transit stations, college campuses, or destination hubs such as a downtown retail area.

## LONG-TERM BICYCLE PARKING DESCRIPTION

### General

- Must provide bicycles with a secure location to park with full weather protection.
- Typically provided at no cost to users.
- Must be located on site, or in a campus environment containing more than one building, such as a hospital or college setting, required long term bicycle parking may be provided up to 600 feet from the land use triggering the bicycle parking requirement.



Wall-mounted racks (Photo: MIG|SvR)

- Consider providing at least 30% of the bicycle parking to allow bicycles to sit horizontally on the ground to accommodate non-standard bicycles and the needs of those who cannot lift a bicycle. Double stack bicycle racks must include an assisted lift mechanism.
- Easily accessible electrical outlets within the long term bicycle parking area can serve rapidly growing e-bike demand.
- Ground-level racks intended to accommodate recumbent bikes, folding bikes, cargo bikes, bikes with trailers, family bikes, etc. should be provided independently of a stacked rack system. Consider providing at least 5% of bicycle parking spaces to accommodate non-standard bikes when more than 20 bicycle parking spaces are required.
- If the bicycle room or cage is not visible from the main bicycle entrance, the route to reach it must be well marked with signage visible from the street.
- If stairs use is necessary to access the long-term bike parking, runnels are required to be provided. Ramps or elevator access should be limited to no more than one floor above or below the main pedestrian entry. Ramps must be no more than 4.8 degree slope to maintain ADA accessibility.
  - If an elevator is required to reach the long-term bicycle parking, elevator cab dimensions should fit a bicycle.
- A plan clearly showing bicycle access routes must be submitted to Seattle Department of Construction and Inspections (SDCI) during building permit review

### Layout

See Appendix D for long-term bike parking layout examples.

- When planning a long term bicycle parking area account for a minimum of 12 sq ft for every required bicycle parking space.

### Convenience of Access

- All bicycle parking is encouraged to be located on the ground floor near the main pedestrian entrances. The long-term bicycle room or cage should be visible from adjacent short-term, on-street bicycle parking facilities.

### Shower and Storage Facilities

- Two showers must be provided for every 100,000 sq ft. of building office space. Showers are for cyclist use and should be located near the long-term bike parking area
- Showers, clothing lockers, and bicycle workstation space is recommended in office, commercial, and retail buildings over 50,000 sq. ft.
- See Seattle Municipal Code 23.54.015, subsection K

### Bicycle Lockers

#### General

- Should be labeled as bicycle parking



*Parking garage with signed bike entrance over a delineated bike path (Photo: Alta Planning + Design)*



*Bicycle lockers protected under building cover (Photo: Alta Planning + Design)*



- Cannot be used for non- bicycle storage if using lockers to satisfy long-term bicycle parking amount

### Location

- Preferably located in covered area for weather protection
- Located on a hard-surfaced area for anchoring

### Dimensions / Layout

- Minimum depth of 6-feet, minimum door width of 2-feet
- Minimum access aisle in width in groups of lockers should be at least of 6-feet wide to allow full door opening

## Bicycle Rooms and Bicycle Cages

### Location

- Located in a well-lit area with a minimum average illumination level of 200 lux (recommended light levels from the US General Services Administration for public areas including stairwells, pedestrian tunnels and bridges, elevator lobbies and corridors [www.gsa.gov/portal/content/101308](http://www.gsa.gov/portal/content/101308))
- If bicycle parking is accessed from garage entry, must have delineated path from garage entry to bicycle parking entry that is separate from path of motor vehicles
- Path or hallway to bike room or cage must be a minimum of 5-feet wide



*Secure parking area at UW (Photo: Alta Planning + Design)*



*Bike room with stacked racks, service station and lockers (Photo: Dero)*

### Security

- The bicycle cage or room must be secured by key, smart card, or code access
- The bicycle cage or room should be under surveillance by attendant, video camera, or, if located in an office, passive surveillance of employees.

### Dimensions / Layout

- Spacing of racks no less than 30-inches
- O.C. or 17-inches O.C. for high density offset arrangements
- Minimum vertical clearance of 7-feet
- Minimum aisle of 5-feet between bicycle racks
- Minimum rack to wall clearance of 2-feet

### Racks

- Racks should be mounted with secure theft resistant anchoring.
- All racks must support a bicycle in two places and a bicycle should be able to lock a front wheel with a U style lock without having to remove the wheel of the bicycle.

### Secure Parking Areas

- May be conditioned or an open air structure
- Enclosure must not permit a 4-inch ball from passing through to prevent unauthorized access
- Must have average illumination of 200 lux

## LONG-TERM BICYCLE PARKING ENHANCEMENTS

- Available electrical outlets for e-bike charging
- Automated doors
- Showers (as enhancements in office, commercial, retail buildings under 100,000 sq. ft.)
- Clothing lockers (as enhancements in office, commercial, retail buildings under 50,000 sq. ft.) and drying rack
- Artwork to enliven space
- Bicycle workstation space (as enhancements in office, commercial, retail buildings under 50,000 sq. ft.)
- Vending Kiosk for bicycle parts
- A community board with information like a city bike map, how to properly lock and register a bicycle, and community notices about upcoming bike events.

## PUBLIC VS. PRIVATE LONG-TERM BICYCLE PARKING

### Public Long-Term Bicycle Parking

- Publicly accessible long-term parking: Transit, Civic Buildings
- City owned and leased properties have set standards to provide bicycle parking and standard racks
- Monitored bicycle parking with public access typically limited to building hours

### Private Long-Term Bicycle Parking

- Privately accessible long-term parking: Residential, office, institutional, healthcare, retail, live-work
- See Seattle Municipal Code for specific locker & shower requirements for building size minimums
- Shall be accessible to building tenants 24 hours a day



*Bicycle cage at the Beacon Hill Light Rail Station (Photo: Alta Planning + Design)*

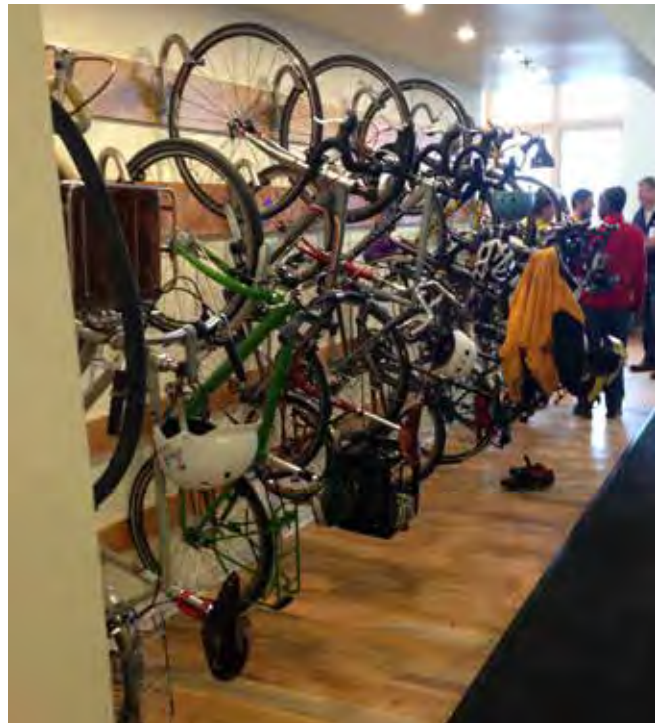

*Parking in clear view of employees (Photo: Alta Planning + Design)*



## GOOD LONG-TERM BICYCLE PARKING EXAMPLES



A variety of rack types including floor racks is provided (Photo: Alta Planning + Design)



Racks are in a secure cage with artwork (Photo: Alta Planning + Design)



SPA with steel bars provides high level of security (Photo: MIG|SvR)



Adequate aisle space provided (Photo: Alta Planning + Design)



Bike room is in a secure, accessible location with signage (Photo: MIG|SvR)



Covered bike lockers at Angle Lake Light Rail Station (Photo: Alta Planning + Design)

## NOT SO GOOD LONG-TERM BICYCLE PARKING EXAMPLES



Anchoring is not theft resistant (Photo: MIG|SvR)



Anchoring and wood mounting is not theft resistant (Photo: MIG|SvR)



Racks are wheel benders (Photo: Alta Planning + Design)



Poor circulation (Photo: Alta Planning + Design)



Racks do not provide 2 points of support & there is no delineated bike exit (Photo: Alta Planning + Design)



Racks do not provide 2 points of support (Photo: Alta Planning + Design)

# 4. BICYCLE RACK EXAMPLES AND SPECIFICATIONS

## OVERVIEW

The following are guidelines for both standard and custom bicycle racks. The goals of the specifications are to provide safe, secure, durable, low-maintenance bike racks and corrals that are easily identifiable as such.

## SPECIFICATIONS

The following are example bike racks that meet SDOT's design standards for bike racks for the ROW.

- **SDOT standard bike racks:**
  - Inverted "U" Bike Rack
  - Rail-Type Bike Rack
- **Example pre-manufactured models**
  - **Manufacturer:** Dero  
Hoop Rack, Swerve Rack, Downtown Rack, Round Rack, Arc Rack
  - **Manufacturer:** Sportworks  
Tofino No Scratch, Oahu No Scratch Circular, Inverted-U Rack
  - **Manufacturer:** HuntCo  
The City of Portland Bike Rack, The Arc Bike Rack

## STANDARD ON-STREET BICYCLE PARKING CORRAL

See Appendix B for City of Seattle standard corral plans and elevations.



*Bike corral on University Way NE (Image: SDOT)*

## CUSTOM BICYCLE RACK

SDOT will review and approve all non-standard bicycle racks in the ROW using the specifications below:

## MINIMUM SPECIFICATIONS

- Have a no-maintenance finish that won't chip, peel, or rust.
- Have a minimum height of 32 inches so it is not a tripping hazard.
- Allow a u-style lock to secure one of the wheels and the frame to the rack.



*Non-standard racks on Blanchard St (Photo: MIG/SvR)*

## GENERAL BEST PRACTICES

- **ADA:** Bike racks must meet ADA 307 (protruding objects) standards when placed in a pedestrian circulation path. Consider including a horizontal crossbar at a low height to make detecting the rack with a cane easier for people with low or no vision.
- **Intuitive:** the rack should be recognizable as a bike rack and intuitive to use correctly.
- **Wheel Protection:** Racks should not bind a front wheel independently of the rest of the bicycle.
- **Adaptability:** Support cargo, adaptive, and family bicycles of various dimensions.



- Safety: all spaces and openings will not cause entrapment issues such as a child's head getting stuck.

## MATERIAL & FINISH BEST PRACTICES

Durable materials and low-maintenance finishes are required for public bicycle racks and are recommended for private bike racks.

- All public bicycle racks must have a no-maintenance finish that won't chip, peel, or rust. Examples include stainless or galvanized steel. Thermoplastic and powder coat finishes are acceptable when full weather protection is provided, or when the provider maintains ownership and maintenance responsibilities.
- Material is durable enough to prevent from being easily cut by a bolt cutter or other means.
- See Appendix E for a table on bike rack materials and finishes.

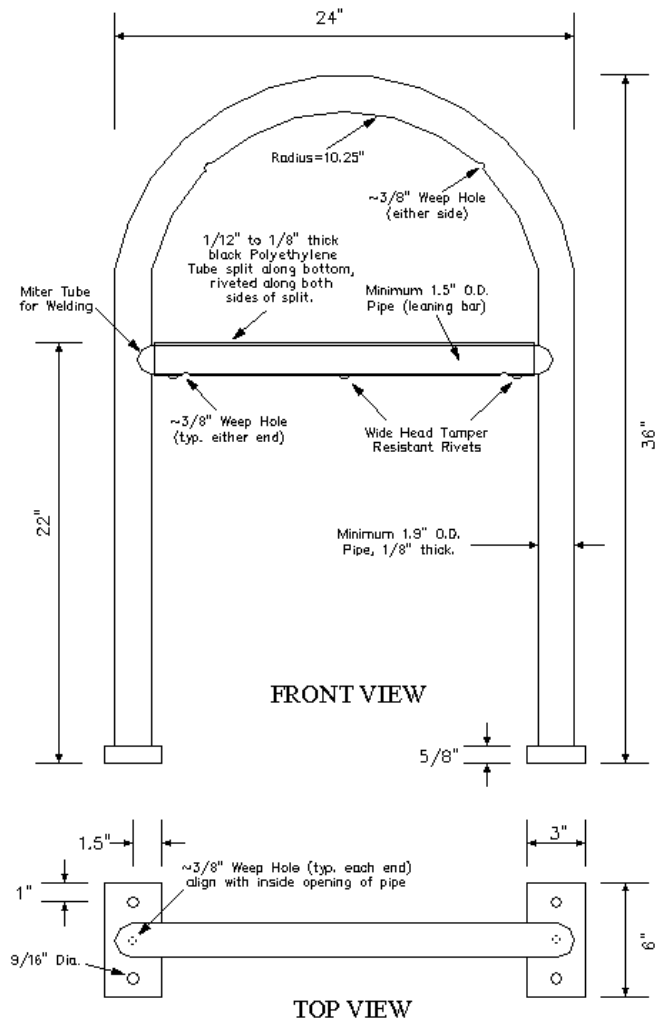

*Inverted "U" Bike Rack (Image: SDOT)*



*Grouped sidewalk bicycle racks on Terry Ave N (Photo: SDOT)*

## MOUNTING / INSTALLATION BEST PRACTICES

Mounting to be tamper proof to prevent thieves from accessing the parked bikes.

- All short-term bicycle racks installed in the public ROW should be installed using surface mounting techniques into concrete. Only multiple bike racks connected together in a bike corral may be installed directly into asphalt.
- If installation is on private property, racks may be embedded into concrete per manufacturer recommendations.
- All hardware should be tamper-proof, low maintenance, and weatherproof.
- Orient racks to allow mounting to mortar if installing racks on brick or other pavers to avoid damaging surface.
- See Appendix F for a table on bike rack installation



*Tamper-proof hardware (Photo: MIG/SvR)*



*Non-standard stainless steel racks on 2nd Ave (Photo: SDOT)*



*On-street bike racks at Bell Street Park (Photo: MIG/SvR)*

# APPENDICES

[Appendix A Additional Resources](#)

[Appendix B City of Seattle Bike Standard Corral Plans and Elevations](#)

[Appendix C Short-Term Bicycle Parking Layout](#)

[Appendix D Bicycle Parking Clearance Examples](#)

[Appendix E Bike Rack Materials and Coatings from APBP](#)

[Appendix F Bike Rack Installation from APBP](#)

# APPENDIX A - ADDITIONAL RESOURCES

The following are additional bike parking and bicycling resources.

- **Seattle Department of Transportation**
  - Bike program page with links to Seattle biking resources including the current Seattle bike map, Seattle bike laws, the bike parking site with information on how to request a bike rack or corral, City standard bike rack details and the site on how to report abandoned bicycles.  
[www.seattle.gov/transportation/projects-and-programs/programs/bike-program/bike-racks](http://www.seattle.gov/transportation/projects-and-programs/programs/bike-program/bike-racks)
  - A guide on securely locking your bike in Seattle:  
[www.seattle.gov/transportation/projects-and-programs/programs/bike-program/bike-security](http://www.seattle.gov/transportation/projects-and-programs/programs/bike-program/bike-security)
  - Interactive [asset map](#) of SDOT bike racks.
- **Seattle Streets Illustrated**

Streets Illustrated is Seattle's Right of Way Improvement Manual, an on-line resource to help property owners, developers, architects, landscape architects, and engineers involved with the design, permitting, and construction of improvements to Seattle's street right-of-way. The manual includes clearance requirements for bicycle parking.  
<https://streetsillustrated.seattle.gov/>
- **City of Seattle Municipal Land Use Code**

Bicycle Parking is under SMC 23.54.015K.  
[https://library.municode.com/wa/seattle/codes/municipal\\_code?nodeId=TIT23LAUSCO](https://library.municode.com/wa/seattle/codes/municipal_code?nodeId=TIT23LAUSCO)
- **Sound Transit**

Bicycle riders guide, bike loading tips video and parking information.  
[www.soundtransit.org/rider-guide/bringing-your-bike](http://www.soundtransit.org/rider-guide/bringing-your-bike)
- **King County Metro**

King County Metro Transit Facility Guidelines with required clearances for bike racks and other features near bus stops  
<https://kingcounty.gov/~media/depts/transportation/metro/about/planning/pdf/2011-21/2018/transit-facilities-guidelines.pdf>
- Bike travel information including parking at transit facilities & how to load your bike on a bus.  
[metro.kingcounty.gov/tops/bike/](http://metro.kingcounty.gov/tops/bike/)
- **Bike Link Secure Bike Parking**

Sign up for a card to rent bike lockers. Lockers in Seattle are currently located at select King County Metro and Sound Transit stations.  
[www.bikelink.org](http://www.bikelink.org)
- **Seattle Police Department (SPD)**

If your bike is lost or stolen, report it to your local precinct to obtain a case file number  
[www.seattle.gov/police/need-help/online-reporting](http://www.seattle.gov/police/need-help/online-reporting)
- **Washington State Dept. of Transportation**
  - Biking resources including Washington State bike map, bike laws, and bike safety tips  
<http://wsdot.wa.gov/bike>



- **Washington State Ferries**  
Information on bike parking, how to ride your bike on a ferry, how to pay your fare  
[www.wsdot.wa.gov/ferries/bicycles](http://www.wsdot.wa.gov/ferries/bicycles)
- **Commuter Seattle**  
Interactive Bike Map that includes trip planning, private bike amenities and public bike parking  
<https://commuteseattle.com/commuteportal/>
- **Seattle Cycling Tours**
  - Interactive map with bike parking in parking garages  
[www.seattle-cycling-tours.com/seattlebicycleparkingguide.html](http://www.seattle-cycling-tours.com/seattlebicycleparkingguide.html)
  - Bicycle parking etiquette  
[www.seattle-cycling-tours.com/bicycleparkingetiquette.html](http://www.seattle-cycling-tours.com/bicycleparkingetiquette.html)
- **Port of Seattle**  
**Sea-Tac Airport Bicycle Resources**  
Information on bike parking at Sea-Tac airport  
[www.portseattle.org/Sea-Tac/Parking-and-Transportation/Ground-Transportation/Pages/Bicycle-Resources.aspx](http://www.portseattle.org/Sea-Tac/Parking-and-Transportation/Ground-Transportation/Pages/Bicycle-Resources.aspx)
- **Bicycle Security Advocates**  
Seattle-based organization that advises on best practices in bicycle security issues, including bike theft and bike parking  
<http://bicyclesecurityadvocates.org/>
- **529 Garage**  
Register your bike  
<https://project529.com>
- **Bike Index**  
Register your bike and information on how to protect your bike.  
<https://bikeindex.org/>
- **Cascade Bicycle Club & Washington Bikes**  
<http://cascade.org/>  
<http://wabikes.org/>
- **Association of Pedestrian and Bicycle Professionals**  
Bicycle parking solutions  
<https://apbp.memberclicks.net/bicycle-parking-solutions>
- **San Francisco Municipal Transportation Agency**  
“Bicycle Parking: Standards, Guidelines, Recommendations” (2015)  
[https://www.sfmta.com/sites/default/files/reports-and-documents/2018/06/1\\_sfmta\\_bicycle\\_parking\\_guidelines-updated-05-15-2018.pdf](https://www.sfmta.com/sites/default/files/reports-and-documents/2018/06/1_sfmta_bicycle_parking_guidelines-updated-05-15-2018.pdf)
- **American Bicyclist Bike Friendly Business**  
Become a League of American Bicyclist Bike Friendly Business  
<http://bikeleague.org/business>
- **American Association of State Highway and Transportation Officials (AASHTO)**  
See AASHTO’s Guide for the Development of Bicycle Facilities (Fourth Edition) for information on bicycle dimensions.  
[www.transportation.org/](http://www.transportation.org/)
- **Bike Link Secure Bicycle Parking**  
Sign up for a card to rent bike lockers by the hour at transit stations. Seattle currently has lockers located at the King County Northgate Transit Center  
[www.bikelink.org](http://www.bikelink.org)

# APPENDIX B - CITY OF SEATTLE STANDARD BIKE CORRAL PLANS & ELEVATIONS

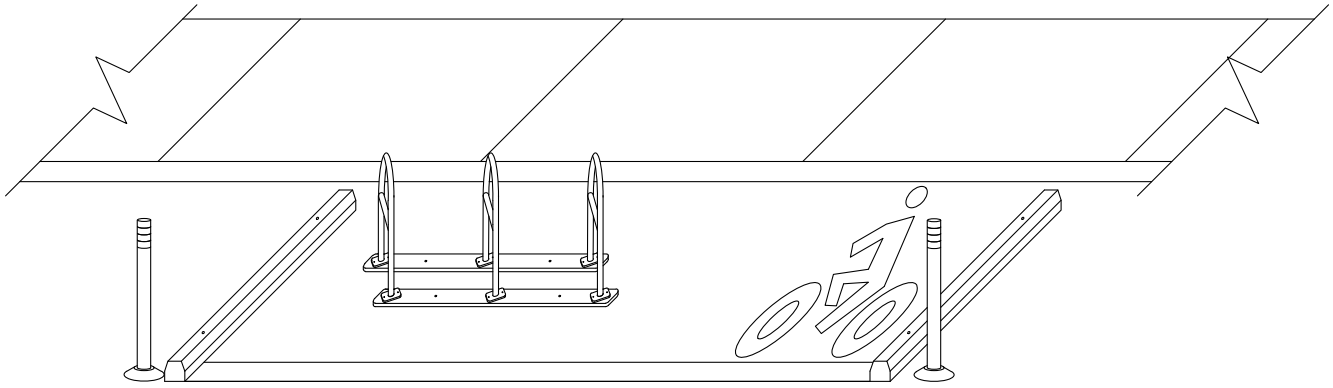

ISOMETRIC VIEW

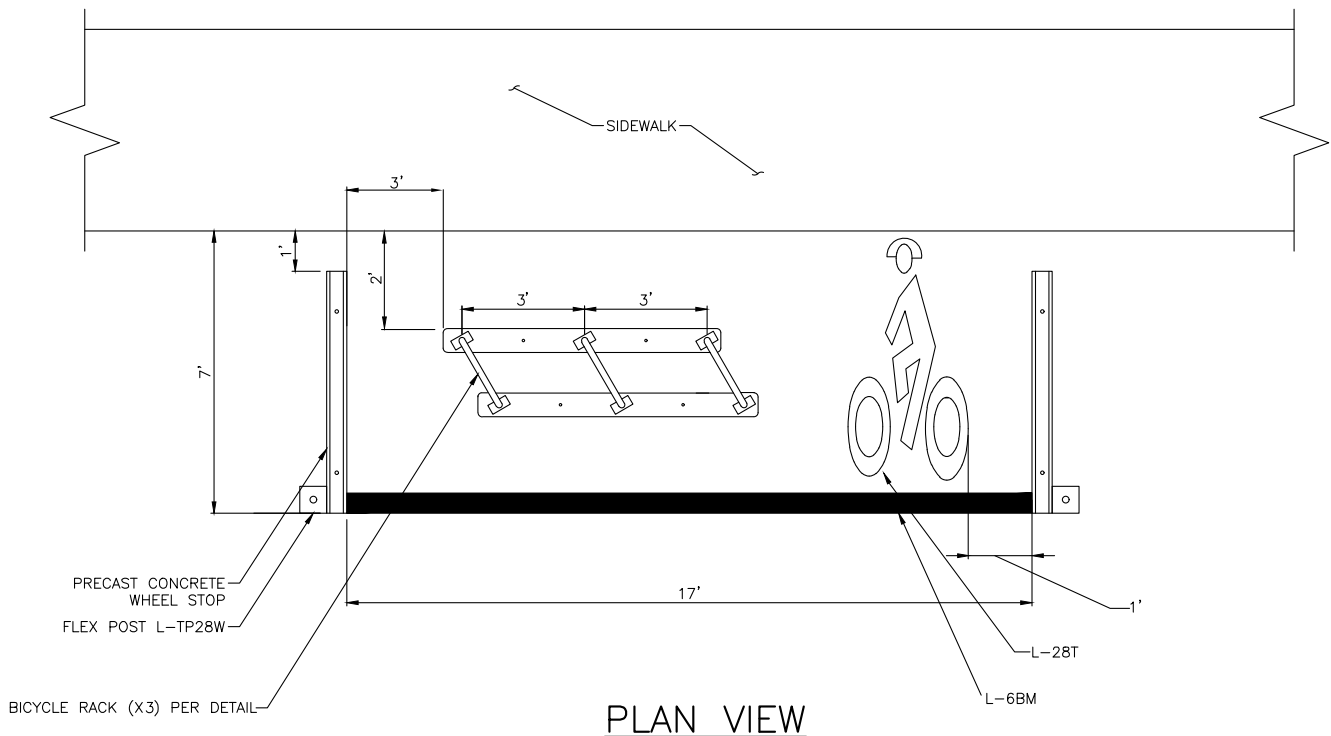

PLAN VIEW

*Single Bike Corral Elevation and Site Plan (Image: SDOT)*

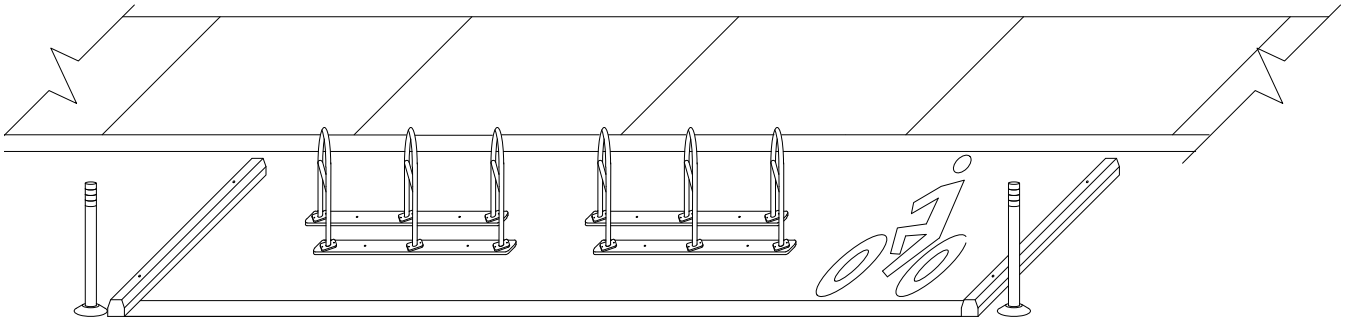

ISOMETRIC VIEW

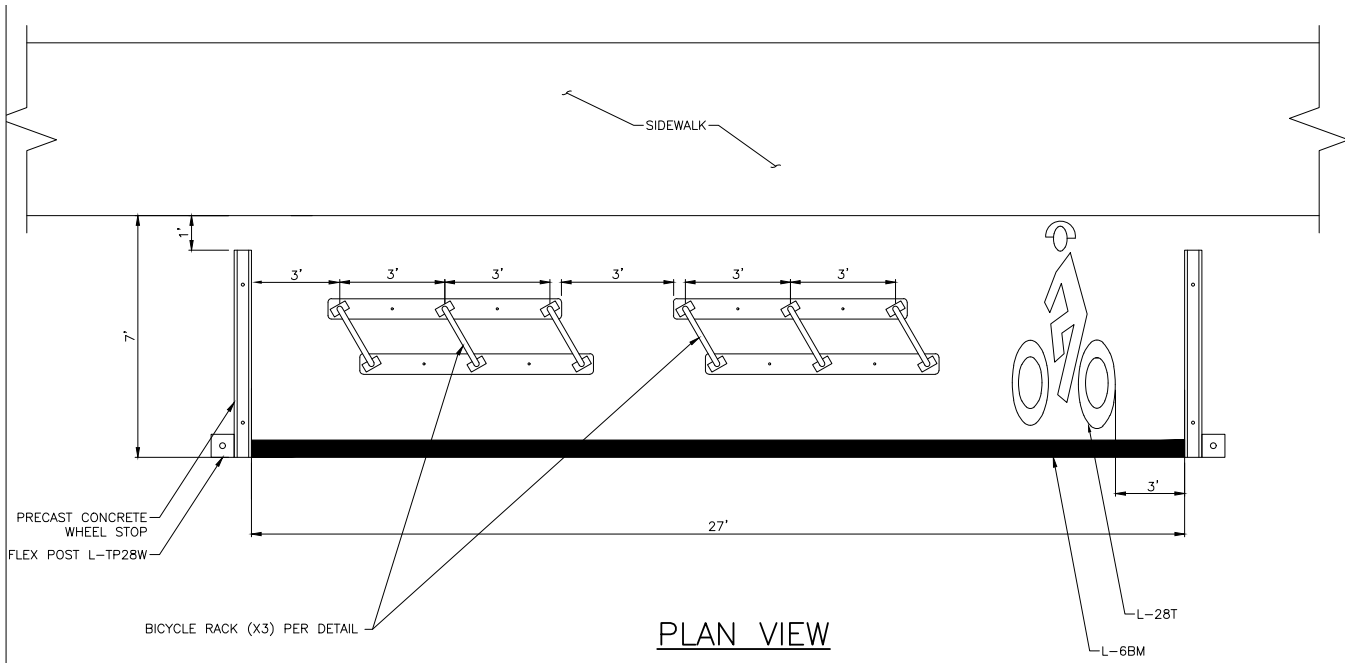

Double Bike Corral Elevation and Site Plan (Image: SDOT)

# APPENDIX C - SHORT-TERM PARKING LAYOUT

Consider a rack fully occupied with a 6'x2' bike parked on both sides of the rack. This creates a 6'x2' operational footprint centered around the rack from which to determine clearances.

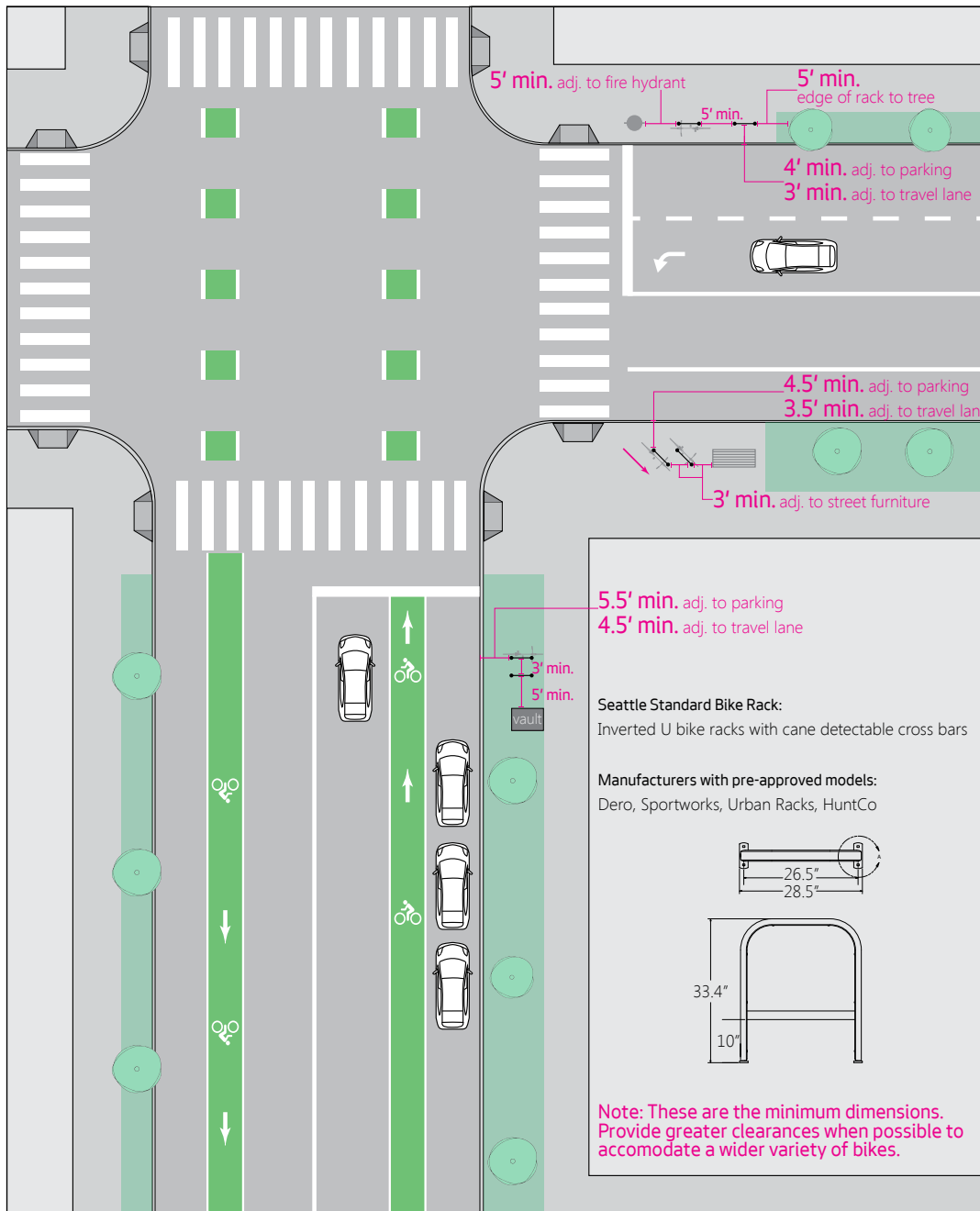

*(Graphic adapted from section 3.3 of the City of Seattle Streets Illustrated Right-of-Way Improvements Manual)*

# APPENDIX D – BICYCLE PARKING CLEARANCE EXAMPLES

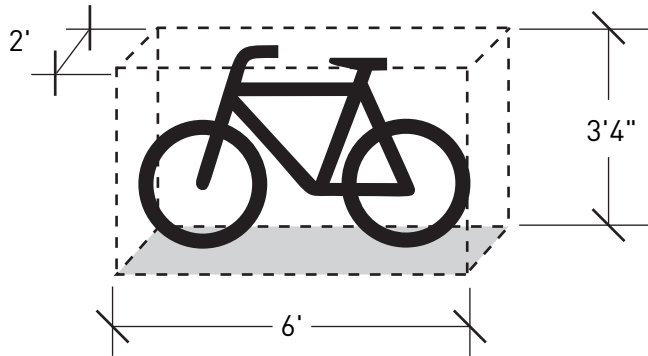

*Horizontal Rack - Single Space: 2 feet wide by 6 feet long by 40 inches in height*

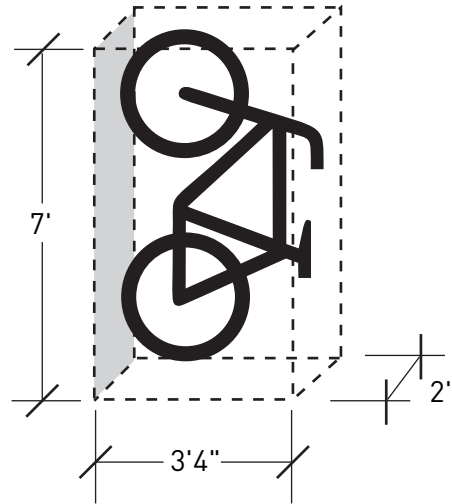

*Vertical Rack - Single Space: 2 feet wide by 40 inches deep by 7 feet in height*

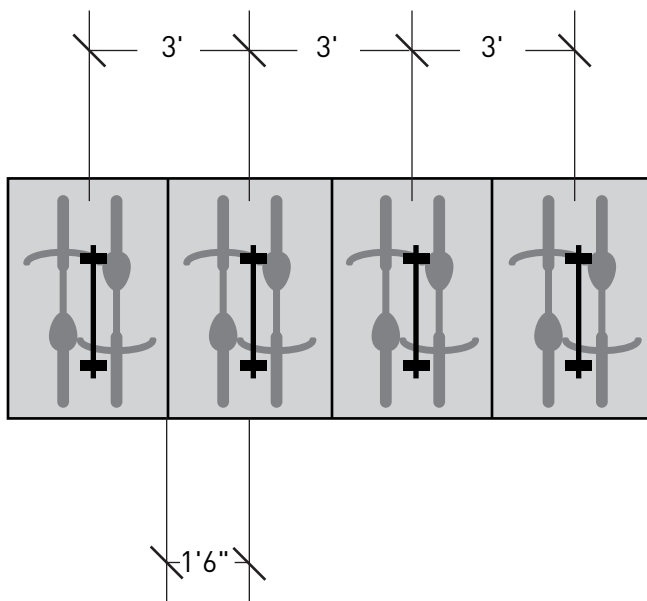

*Horizontal Rack - Side-by-Side Spaces: 18 inches wide by 6 feet long by 40 inches in height*

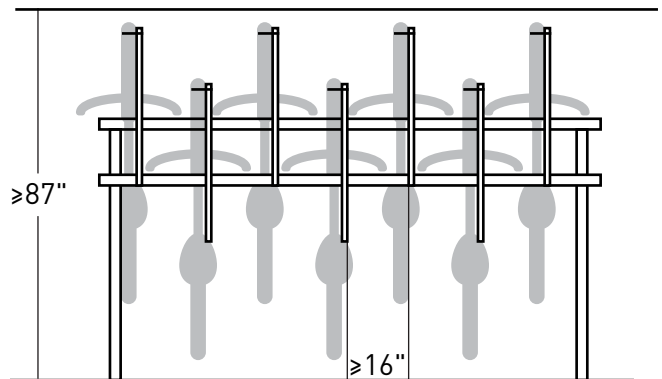

*Vertical Rack - Multiple (Alternating): 16 inches wide by 40 feet inches deep by 87 inches in height*

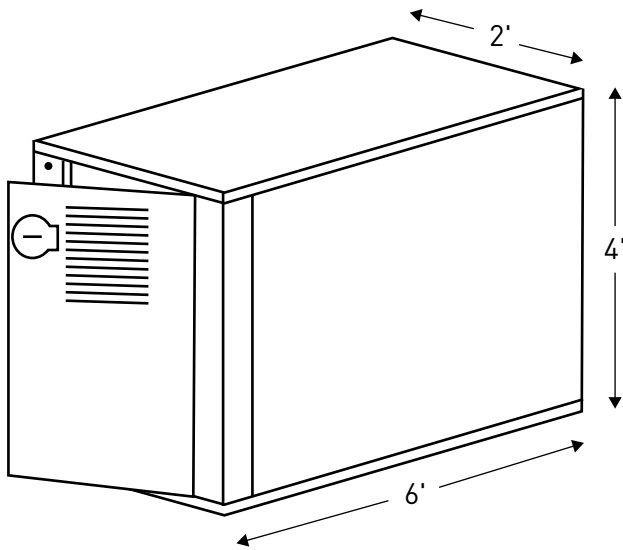

*Bicycle Locker - Single: minimum access door of 2 feet wide with internal dimensions of 6 feet long and 4 feet in height*

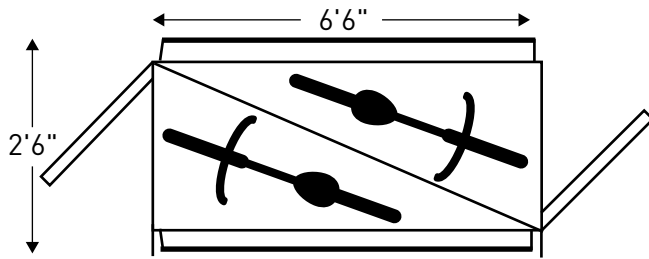

*Bicycle Locker - Double: minimum access door of 2 feet wide with minimum internal dimensions of 2 feet-6 inches wide by 6 feet-6 inches long (when the locker divides the bicycle parking space into two triangular shaped spaces) by 4 feet in height*

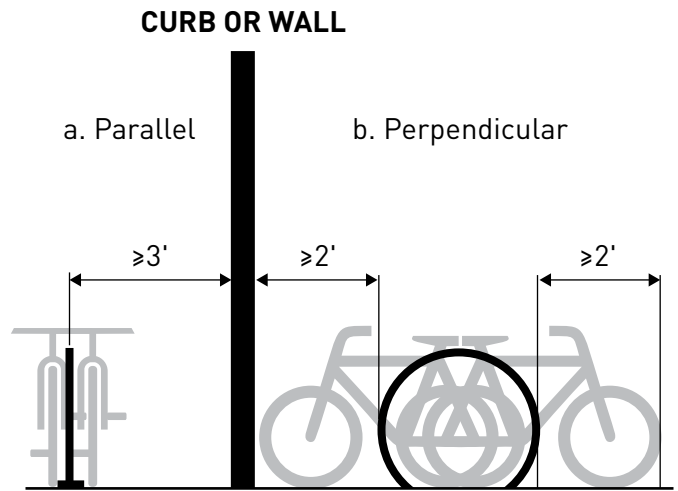

*Clearance - Horizontal rack clearance from vertical obstructions: When parallel to a wall and providing two parking spaces, a horizontal rack must be at least 3 feet away from any vertical obstruction. If less than 3 feet are provided, such placement satisfies only one required bicycle parking space (on the side opposite the vertical obstruction). When perpendicular to a wall, the rack must be at least 2 feet away from the vertical obstruction*

# APPENDIX E - BIKE RACK MATERIAL AND COATINGS FROM APBP

<b>RACK MATERIAL - COATING</b>	<b>RELATIVE PURCHASE COST</b>	<b>DURABILITY</b>	<b>CAUTIONS</b>
<b>Carbon steel - galvanized</b>	Usually lowest	Highly durable and low-maintenance; touch-up, if required, is easy and blends seamlessly	Utilitarian appearance; can be slightly rough to the touch
<b>Carbon steel - powder coat* (TGIC or similar)</b>	Generally marginally higher than galvanized	Poor durability	Requires ongoing maintenance; generally not durable enough for long service exposed to weather; not durable enough for large-scale public installations
<b>Carbon steel - thermoplastic</b>	Intermediate	Good durability	Appearance degrades over time with scratches and wear; not as durable as galvanized or stainless
<b>Stainless steel - no coating needed, but may be machined for appearance</b>	Highest	Low-maintenance and highest durability; most resistant to cutting	Can be a target for theft because of salvage value; maintaining appearance can be difficult in some locations

\* When applied to carbon steel, TGIC powder coat should be applied over a zinc-rich primer or galvanization to prevent the spread of rust beneath the surface or at nicks in the finish.

*(Graphic courtesy Association of Pedestrian and Bicycle Professionals Essentials of Bike Parking report (2015))*

# APPENDIX F - BIKE RACK INSTALLATION FROM APBP

## INSTALLATION SURFACE

A sturdy concrete pad is an ideal surface for installing bicycle parking. Other surfaces often encountered include asphalt, pavers, and soft surfaces such as earth or mulch. These surfaces can accommodate in-ground mounting or freestanding bike racks such as inverted-U racks mounted to rails. See APBP's *Bicycle Parking Guidelines* for details. [↪ apbp.org](https://apbp.org)

## INSTALLATION FASTENERS

When installing racks on existing concrete, consider the location and select appropriate fasteners. Drill any holes at least three inches from concrete edges or joints. Some locations benefit from security fasteners such as concrete spikes or tamper-resistant nuts on wedge anchors. Asphalt is too soft to hold wedge and spike anchors designed for use in concrete. Installing bike parking on asphalt typically requires freestanding racks and anchor techniques specific to asphalt.

### FASTENERS

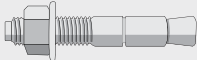
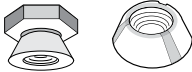
<b>CONCRETE SPIKE</b>		Installs quickly in concrete with a hammer. Tamper-resistant. Removal may damage concrete and/or rack.
<b>CONCRETE WEDGE ANCHOR</b>		Allows for rack removal as needed. Not tamper-resistant, but can accommodate security nuts (below).
<b>SECURITY NUTS</b>		Use with concrete wedge anchors. Security nuts prevent removal with common hand tools.

## INSTALLATION TECHNIQUES

When installing racks on existing concrete, choose those with a surface-mount flange and install with a hammer drill according to the specifications of the mounting hardware selected. When pouring a new concrete pad, consider bike parking fixtures designed to be embedded in the concrete. Because replacing or modifying an embedded rack is complicated and costly, this installation technique requires particular attention to location, spacing, rack quantity, and material.

*(Graphic adapted from Association of Pedestrian and Bicycle Professionals Essentials of Bike Parking report (2015))*





The Seattle Department of Transportation  
700 5th Avenue, Suite 3800  
PO Box 34996  
Seattle, WA 98124-4996  
(206) 684-ROAD (7623)  
[www.seattle.gov/transportation](http://www.seattle.gov/transportation)



**Seattle**  
Department of  
Transportation

10.2020